

CIVIL ENGINEERING

Design of Steel Structures



Comprehensive Theory
with Solved Examples and Practice Questions





MADE EASY Publications Pvt. Ltd.

Corporate Office: 44-A/4, Kalu Sarai (Near Hauz Khas Metro Station), New Delhi-110016 | **Ph. :** 9021300500

Email : infomep@madeeasy.in | **Web :** www.madeeasypublications.org

Design of Steel Structures

© Copyright, by MADE EASY Publications Pvt. Ltd.

All rights are reserved. No part of this publication may be reproduced, stored in or introduced into a retrieval system, or transmitted in any form or by any means (electronic, mechanical, photo-copying, recording or otherwise), without the prior written permission of the above mentioned publisher of this book.



MADE EASY Publications Pvt. Ltd. has taken due care in collecting the data and providing the solutions, before publishing this book. In spite of this, if any inaccuracy or printing error occurs then **MADE EASY Publications Pvt. Ltd.** owes no responsibility. We will be grateful if you could point out any such error. Your suggestions will be appreciated.

EDITIONS

First Edition: 2015
Second Edition: 2016
Third Edition: 2017
Fourth Edition: 2018
Fifth Edition: 2019
Sixth Edition: 2020
Seventh Edition: 2021
Eighth Edition: 2022
Ninth Edition: 2023

Tenth Edition: 2024

CONTENTS

Design of Steel Structures

CHAPTER 1

Introduction 1-15

1.1	Steel as a Structural Material	1
1.2	Rolled Steel Sections	2
1.3	Local Buckling	4
1.4	Classification of Cross-section	6
1.5	Modes of Failure in Beam	8
1.6	Loads	10
1.7	Reactions Due to Actions on Structure	10
1.8	Design of Steel Structures	10
1.9	Limit State Design	11
	<i>Objective Brain Teasers</i>	14
	<i>Conventional Brain Teasers</i>	15

CHAPTER 2

Riveted, Bolted & Pinned Connections 16-58

2.1	Introduction	16
2.2	Riveted Connection	16
2.3	Bolted Connection	18
2.4	Mechanism of Load Transfer Through Bolts	26
2.5	Failure of Bolted Joints	26
2.6	Specifications for the Bolted Joints	27
2.7	Bearing Type Connection	31
2.8	Tensile Strength of Plate	35
2.9	Strength and Efficiency of a Bolted Joint	36
2.10	Combined Tension and Shear	40

2.11	Slip Critical Connection	40
2.12	Prying Action	43
2.13	Pin Connections	46
	<i>Objective Brain Teasers</i>	49
	<i>Conventional Brain Teasers</i>	57

CHAPTER 3

Welded Connections 59-89

3.1	Introduction	59
3.2	Types of Welded Joints	59
3.3	Weld Symbols	61
3.4	Weld Defects	61
3.5	Inspection of Welds	62
3.6	Assumptions in the Analysis of Welded Joints	62
3.7	Butt (or Groove) Welds	62
3.8	Fillet Weld	65
3.9	Fillet Weld for Truss Members	71
3.10	Intermittent Fillet Weld	73
3.11	Slot and Plug Weld	74
3.12	Combination of Stresses	76
3.13	Weld Failure	76
3.14	Advantages of Fillet Weld over Butt Weld	78
3.15	Comparison between Welded Joints and Bolted/ Riveted Joints	78
	<i>Objective Brain Teasers</i>	79
	<i>Conventional Brain Teasers</i>	87

CHAPTER 4**Tension Members90-122**

4.1	Introduction	90
4.2	Various Types of Tension Members	91
4.3	Net Sectional Area of Tension Members (A_N).....	92
4.4	Net Effective Area of Tension Members (A_{NE}).....	94
4.5	Different Types of Failure in Tension Members.....	95
4.6	Design Strength of a Tension Member	96
4.7	Slenderness Ratio of Tension Members.....	105
4.8	Procedure for the Design of Tension Member	105
4.9	Splicing in Tension Member	107
4.10	Lug Angles	108
4.11	Gusset Plate	111
	<i>Objective Brain Teasers</i>	112
	<i>Conventional Brain Teasers</i>	119

CHAPTER 5**Compression Members.....123-176**

5.1	Introduction	123
5.2	Different Types of Compression Member	123
5.3	Design Aspects of Compression Member	123
5.4	Effective Length	124
5.5	Slenderness Ratio (λ).....	127
5.6	Types of Sections for Compression Members.....	128
5.7	Various Types of Buckling	129
5.8	Elastic and Inelastic Buckling of Columns	130
5.9	Column Formula	133
5.10	Design Strength of Axially Loaded Compression Member.....	142
5.11	Procedure for the Design of Axially Loaded Compression Member	143

5.12	Built-up Columns.....	144
5.13	Lacing	145
5.14	Batten.....	154
5.15	Column Splices	157
	<i>Objective Brain Teasers</i>	159
	<i>Conventional Brain Teasers</i>	172

CHAPTER 6**Beams..... 177-219**

6.1	Introduction	177
6.2	Types of Beam Sections.....	177
6.3	Classification of Beam Cross-sections	179
6.4	Different Types of Elements of a Cross-section.....	179
6.5	Lateral Stability of Beams	179
6.6	Elastic Critical Moment.....	181
6.7	Strength of Beams in Bending.....	186
6.8	Flexural Strength of Laterally Supported Beam	187
6.9	Shear Strength of Beam	190
6.10	Limits on Deflection of Beam.....	192
6.11	Buckling Strength of Web.....	193
6.12	Web Crippling	195
6.13	Procedure for the Design of Beams	195
6.14	Design of Built-up Beams	202
6.15	Design of Laterally Unsupported Beams	202
6.16	Effective Length of Laterally Unsupported Beams...	203
6.17	Design of Laterally Unsupported Beam : Purlin	204
6.18	Design of Laterally Unsupported Beam: Grillage Beams.....	205
6.19	Design of Built-up beams/plated beams	205
	<i>Objective Brain Teasers</i>	210
	<i>Conventional Brain Teasers</i>	214

CHAPTER 7**Column Bases and Foundations..... 220-251**

7.1	Introduction	220
7.2	Types of Column Bases	221
7.3	Slab Base.....	223
7.4	Gusset Base.....	231
7.5	Moment Resisting Base Plate and its Design.....	237
7.6	Foundation Bolts	241
	<i>Objective Brain Teasers.....</i>	247
	<i>Conventional Brain Teasers.....</i>	249

CHAPTER 8**Plate Girder..... 252-289**

8.1	Introduction	252
8.2	Elements of a Plate Girder	253
8.3	Self-weight of a Plate Girder	254
8.4	Depth of Web	254
8.5	Web Thickness	256
8.6	Size of Flanges	257
8.7	Flexural Strength	258
8.8	Shear Strength of Web.....	259
8.9	Design of Web for Shear Buckling	263
8.10	Design of End Panel.....	265
8.11	Stiffeners.....	267
8.12	Intermediate Web Stiffener.....	275
8.14	Bearing Stiffeners	278
8.15	Diagonal Stiffeners.....	280

8.16	Tension Stiffener	280
8.17	Torsional Stiffener.....	280
8.18	Design Steps for a Plate Girder	281
	<i>Objective Brain Teasers.....</i>	282
	<i>Conventional Brain Teasers.....</i>	287

CHAPTER 9**Gantry Girder 290-305**

9.1	Introduction	290
9.2	Loads for Gantry Girders	291
9.3	Specification for Gantry Girders.....	294
9.4	Procedure for the Design of Gantry Girders	295
	<i>Objective Brain Teasers.....</i>	303
	<i>Conventional Brain Teasers.....</i>	305

CHAPTER 10**Members Carrying Combined Axial Load and Moments..... 306-323**

10.1	Introduction	306
10.2	Order of Moments.....	306
10.3	Beam-Column Behaviour	310
10.4	Strength of Beam-Column	311
10.5	Check for Local Section Capacity.....	312
10.6	Check for Overall Strength of Member.....	313
10.7	Procedure for the Design of Beam Columns	315
10.8	Procedure for the Design of Tension Members Subjected to Axial load and Bending Moment	316
	<i>Objective Brain Teasers.....</i>	323

CHAPTER 11**Eccentric and Moment Connections 324-364**

11.1 Introduction	324
11.2 Beam Column Connections	328
11.3 Connection Subjected to Eccentric Shear	330
11.4 Framed Connection-Bolted	331
11.5 Seat Connection-Bolted	332
11.6 Bolted Bracket Connection	335
11.7 Welded Bracket Connection	345
<i>Objective Brain Teasers</i>	352
<i>Conventional Brain Teasers</i>	361

CHAPTER 12**Plastic Analysis and Design 365-409**

12.1 Introduction	365
12.2 Idealised Stress Strain Curve For Mild Steel	365
12.3 Assumptions in the Plastic Analysis of Beams	
Theory of Plastic Bending	366
12.4 Plastic Moment Carrying Capacity of a section	367
12.5 Shape Factor	368
12.6 Load Factor	370
12.7 Moment Curvature Relationship	371
12.8 Plastic Hinge	372
12.9 Hinge Length	373

12.10 Mechanism	374
12.11 Plastic Collapse	376
12.12 Fundamental Conditions in Plastic Analysis	377
12.13 Theorem of Plastic Analysis	377
12.14 Principle of Virtual Work	378
12.15 Static Method	378
12.16 Kinematic Method (Mechanism Method)	379
12.17 Advantages & Disadvantages of Plastic Design over Elastic Design	383
12.18 Some Important Aspects of Plastic Design and Elastic Design	383
12.19 Collapse Load of Some Standard Cases	384
<i>Objective Brain Teasers</i>	390
<i>Conventional Brain Teasers</i>	402

CHAPTER 13**Industrial Roof Truss 410-420**

13.1 Introduction	410
13.2 Planning	410
13.3 Components of an Industrial Shed	411
13.5 Roof Trusses	412
<i>Objective Brain Teasers</i>	418

CHAPTER 14**Appendix
(Important clauses of IS 800 : 2007).. 421-430**

Introduction

1.1 STEEL AS A STRUCTURAL MATERIAL

Advantages of steel as a structural material:

- (a) As compared to other structural materials steel has high strength to weight ratio. It implies, steel possess very high strength and results in smaller sections as compared to other structural materials. Thus steel is particularly useful for carrying heavy loads with relatively small sections.
- (b) Being light, steel can be handled conveniently and thus it offers ease in transportation.
- (c) Another important property of steel is that it is ductile. Due to this very useful property it does not fail abruptly but gives ample warning by yielding before actual collapse of the structure.
- (d) Steel possess very high strength also due to which it does not undergo fracture due to large deformation and erection stresses.
- (e) Steel has a very long life when maintained properly.
- (f) Retrofitting of steel structures is quite easy as compared to other materials like RCC, timber, mortar etc.
- (g) The resale value of steel is also very high amongst all building materials. Moreover, steel can be reused also.

Disadvantages of steel as a structural material:

- (a) Steel when placed in exposed conditions is prone to corrosion. Thus steel structures require proper protection measures to be adopted right from its manufacturing.
- (b) Steel is prone to fire and its strength reduces considerably due to high temperatures and thus steel structures require separate fire-proof treatment which ultimately adds to the cost of the structure.
- (c) Steel structures when subjected to cyclic loading (like turbo-generators of power plants etc.) and reversal of stresses undergo fatigue. This fatigue results in reduction of the strength of the steel.
- (d) Under certain conditions particularly at locations of stress concentrations, steel may lose its ductility which gets enhanced at low temperatures and under fatigue loading.
- (e) In steel construction, the designer is not having too many options as in RCC as far as size of the section is concerned. The designer is compelled to use the available standard rolled sections.

BIS classifies structural steel on the basis of its ultimate strength or the yield strength. The chemical composition, rolling methods, heat treatment and stress history etc. of steel determines its mechanical properties.

Some of the mechanical properties of steel are:

(a) Modulus of elasticity or Young's modulus (E)		$2 \times 10^5 \text{ N/mm}^2 = 200 \text{ kN/mm}^2$
(b) Poisson's ratio (μ)	Elastic range	0.3
	Plastic range	0.5
(c) Shear modulus (G)		$0.77 \times 10^5 \text{ N/mm}^2 = 77 \text{ kN/mm}^2$
(d) Mass density (ρ)		7850 kg/m^3
(e) Coefficient of thermal expansion (α)		$12 \times 10^{-6} \text{ }^\circ\text{C}^{-1}$
(f) Yield stress (f_y)		$220 - 540 \text{ N/mm}^2$
(g) Ultimate tensile strength		$1.2 f_y$

1.2 ROLLED STEEL SECTIONS

The Bureau of Indian Standards (BIS) publishes **IS Handbook No.1** that tabulates weight per unit length, geometric dimensions and other dimensions for various types of steel sections.

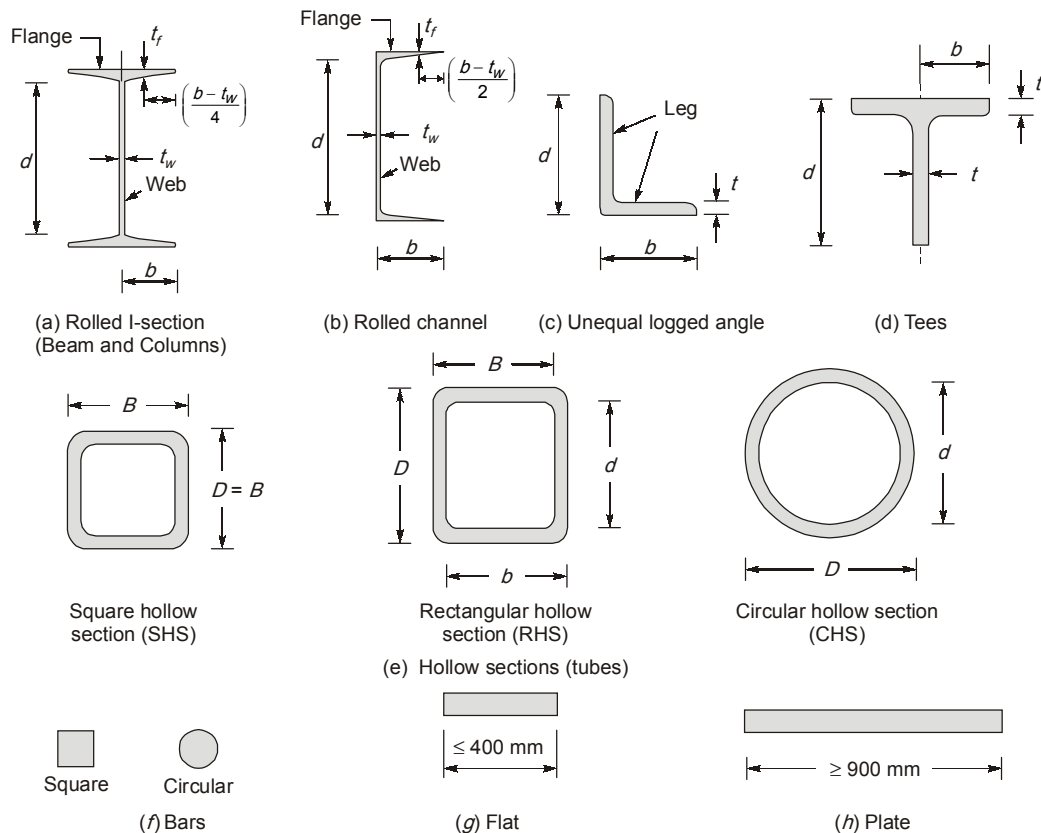

Fig. : Rolled structural steel sectional shapes

Commonly used sections are:

- | | |
|--|--|
| (a) Hot rolled steel I-section Fig. (a) | (b) Hot rolled steel channel section Fig. (b) |
| (c) Hot rolled steel angle section Fig. (c) | (d) Hot rolled steel tee (T) section Fig. (d) |
| (e) Hot rolled steel tube section Fig. (e) | (f) Hot rolled steel bars Fig. (f) |
| (g) Hot rolled steel flats Fig. (g) | (h) Hot rolled steel plates Fig. (h) |
| (i) Hot rolled steel sheets | (j) Hot rolled steel strips |

1.2.1 Designation of Some Indian Standard Rolled Steel Sections

- (a) ISJB : Indian Standard Junior Beam
- (b) ISLB : Indian Standard Light Beam
- (c) ISMB : Indian Standard Medium Beam
- (d) ISHB : Indian Standard Heavy Beam (mostly used as column section)
- (e) ISWB : Indian Standard Wide Flange Beam
- (f) ISJC : Indian Standard Junior Channel
- (g) ISLC : Indian Standard Light Channel
- (h) ISMC : Indian Standard Medium Channel
- (i) ISSC : Indian Standard Special Channel
- (j) ISJT : Indian Standard Junior T Bar
- (k) ISNT : Indian Standard Normal T Bar
- (l) ISHT : Indian Standard Wide Flange T Bar
- (m) ISST : Indian Standard Long Legged T Bar
- (n) ISLT : Indian Standard Light T Bar
- (o) ISA : Indian Standard Angle (both equal and unequal legged)
- (p) ISBA : Indian Standard Bulb Angle
- (q) ISRO : Indian Standard Round Bar
- (r) ISSQ : Indian Standard Square Bar
- (s) ISPL : Indian Standard Plate
- (t) ISF : Indian Standard Flat
- (u) ISSH : Indian Standard Sheet
- (v) ISST : Indian Standard Strip



All standard I and channel sections have a slope of $16\frac{2}{3}\%$ on the inner face of the flange.

1.2.2 Sign Convention for Member Axes

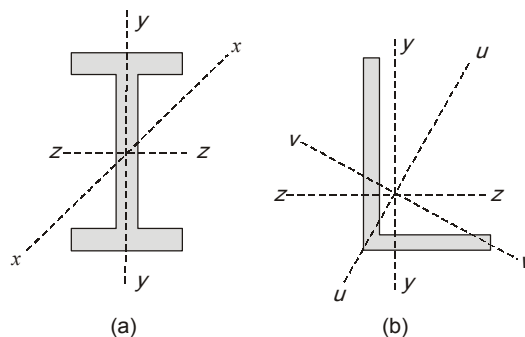

Fig. Member axes notation

x-x	Longitudinal axis i.e. axis along the member
y-y	Axis in the plane of the cross section which is: (a) normal to the flanges [Fig. (a)] (b) normal to the smaller leg in angle sections [Fig. (b)]
z-z	Axis in the plane of the cross section which is: (a) parallel to the flanges [Fig. (a)] (b) parallel to the smaller leg in angle sections [Fig. (b)]
u-u	Major axis in case it does not coincide with the z-z axis [Fig. (b)]
v-v	Minor axis in case it does not coincide with the y-y axis [Fig. (b)]

1.3 LOCAL BUCKLING

- Most of the structural sections whether hot rolled or cold rolled are made of plate elements be it channel section, angle section, T-section, I-section and so on.
- These individual plate elements are joined together to form the desired section.
- When any of these sections is subjected to compressive stresses (direct compressive stress, flexural compressive stress etc.) then stability of its component plate elements must be ensured.
- The thin plate elements may buckle locally out of their original straight plane when subjected to compressive stresses.
- Local buckling adversely affects the load carrying capacity of the section. Buckling affects the strength of section in the following ways:
 - (a) Buckling may lead to overall failure of the structure rendering the plate element to be ineffective.
 - (b) Buckling may give rise to redistribution of stresses and thus affects the load carrying capacity of the section.

The effect of local buckling of plate element on the strength of the whole structure depends on the location of buckled element, its buckling and post buckling characteristics and the type of structural member.

- For uniform compression and pure bending, the critical stress is given by,

$$f_{cr} = \frac{K\pi^2 E}{12(1-\mu^2)\left(\frac{b}{t}\right)^2} \quad \dots(1.1)$$

- For pure shear, the critical stress is given by,

$$\tau_{cr} = \frac{K\pi^2 E}{12(1-\mu^2)\left(\frac{d}{t_w}\right)^2} \quad \dots(1.2)$$

Where K = Buckling constant which depends on the support conditions and ratio of length to width of the plate.

b = Width of the plate, t = Thickness of the plate

E = Modulus of elasticity of steel i.e. Young's modulus, μ = Poisson's ratio

From Eq. (1.1) and (1.2) it can be deduced that fundamentally there is no difference between the buckling phenomena as represented by these two equations. In case of pure shear, buckling takes place due to inclined compressive stress which tries to create diagonal compressive waves in the plate.

1.3.1 Prevention of Local Buckling

The local buckling can be prevented by adopting a higher thickness value for the plate element. IS 800:2007 puts a limit on width to thickness ratio of component steel plates of the section as given in **Table below**.

Limiting width-to-thickness ratio						
Compression Element		Ratio	Class of Section			
			Class 1 Plastic	Class 2 Compact	Class 3 Semi-Compact	
Outstanding element of compression flange	Rolled section	bt_f	9.4ε	10.5ε	15.7ε	
	Welded section	bt_f	8.4ε	9.4ε	13.6ε	
Internal element of compression flange	Comp. due to bending	bt_f	29.3ε	33.5ε	42ε	
	Axial compression	bt_f	Not applicable			
Web of an I-H-or box Section	Neutral axis at mid-depth	dt_w	84ε	105ε	126ε	
	Generally	If r_1 is negative	$\frac{84ε}{1 + r_1}$	$\frac{105ε}{1 + r_1}$	$\frac{126ε}{1 + 2 r_2}$ but ≤ 40ε	
		If r_2 is negative	dt_w	but ≤ 40ε		$\frac{105ε}{1 + 1.5r_1}$ but ≤ 40ε
	Axial compression		dt_w	Not applicable		42ε
Web of a channel		dt_w	42ε	42ε	42ε	
Angle, compression due to bending (both criteria should be satisfied)		bt	9.4ε	10.5ε	15.7ε	
		dt	9.4ε	10.5ε	15.7ε	
Single angle, or double angles with the components separated, axial compression (All three criteria should be satisfied)		bt	Not applicable		15.7ε	
		dt			15.7ε	
		$(b + d)/t$			25ε	
Outstanding leg of an angle in contact back-to-back in a double angle member		dt	9.4ε	10.5ε	15.7ε	
Outstanding leg of an angle with its back in continuous contact with another component		dt	9.4ε	10.5ε	15.7ε	
Stem of a T-section, rolled or cut from a milled I or H-section		Dt_f	8.4ε	9.4ε	18.9ε	
Circular hollow tube, including welded tube subjected to:		(a) Moment	Dt	$42ε^2$	$52ε^2$	$146ε^2$
		(b) axial compression	Dt	Not applicable		$88ε^2$
Circular hollow section	Compression due to bending	Dt	$42ε^2$	$52ε^2$	$88ε^2$	
Mix-rolled rectangular hollow section (RHS)	Flange: compression due to bending Web: neutral axis at mid-depth Generally	dt	29.3ε	33.5ε	42ε	
		dt	67.1ε	84ε	125.9ε	
		dt	$\frac{64ε}{(1 + 0.6 r_1)}$ but < 40ε	$\frac{84ε}{(1 + r_1)}$ but < 40ε	$\frac{125.9ε}{(1 + 2 r_1)}$ but < 40ε	

$$\epsilon = \sqrt{\frac{250}{f_y}}$$



IS 800:2007 specifies no limit on minimum thickness requirement of steel sections but however a minimum thickness of 6 mm for main members and 5 mm for secondary members must be used in steel design and construction. This minimum thickness is required for better performance under adverse environmental conditions. In addition to that, steel in contact with water and soil and those subjected to alternate wetting and drying, an additional thickness of 1.5 mm should be provided.

- **Internal Elements:** These are the elements which are attached along both the longitudinal edges to other elements or to the longitudinal stiffeners connected at adequate intervals to the transverse stiffeners e.g. web of I-section and flanges and web of box section.
- **Outstand Elements:** These are also called as outstands and are attached only to one of the longitudinal edges to an adjacent element and the other edge is being free to get displaced out of its plane e.g. flange overhang of an I-section and legs of an angle section.

1.4 CLASSIFICATION OF CROSS-SECTION

- The phenomenon of local buckling imposes a limit to the extent to which sections can be made thin walled.

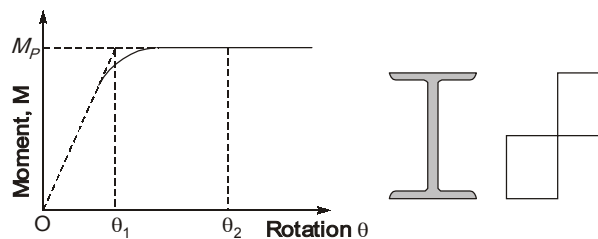

Fig.: Elastic-plastic moment rotation curve

- The classification of cross-sections is done on the basis of moment rotation characteristics as shown in figure of *elasto-plastic moment rotation curve* assuming that the flange or web plate does not buckle locally.

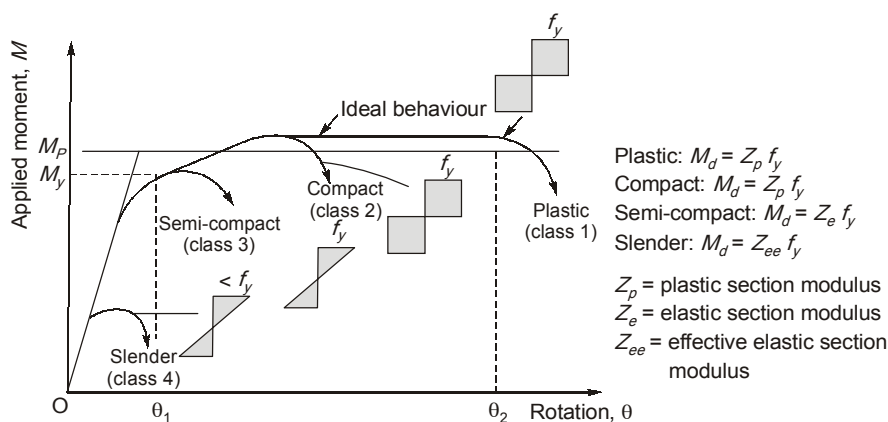

Fig. : Moment rotation characteristics of four classes of cross section

- It is essential to classify sections on the basis of their tendency to buckle locally before overall failure of member takes place.

1.4.1 Basis of Section Classification

- The plate elements of the cross section being thin may buckle locally about their weak axis especially due to compressive stresses. This local buckling can be avoided before a limit state is reached by limiting the width to thickness ratio of each element of the cross section subjected to compressive load, moment and shear.
- When plastic analysis is used, members must be capable of forming the plastic hinges with sufficient rotation capacity (i.e. ductility) without local buckling to enable the redistribution of bending moment required before formation of failure mechanism.
- When elastic analysis is used, the member must be capable of developing the yield stress under compression without undergoing local buckling.

Based on these considerations, four classes of sections are mentioned in **Table below**

Cross-section classification and their characteristics		
S.No.	Types of Sections	Characteristics
1.	Plastic (Class 1)	<ul style="list-style-type: none"> • Cross sections, which can develop plastic hinges and have the rotation capacity required for failure of the structure by formation of a plastic mechanism, are called plastic sections. These sections are used in plastic analysis and design. • These sections are used in indeterminate frames forming plastic collapse mechanism. • The stress distribution for these sections is rectangular.
2.	Compact (Class 2)	<ul style="list-style-type: none"> • Cross sections, which can develop plastic moment of resistance, but have inadequate plastic hinge rotation capacity for formation of a plastic mechanism before buckling are referred to as compact sections. • These cross sections may develop full plastic stress distribution across the entire cross-section but do not have adequate ductility. • For a section to be compact, its compression elements must have width-to-thickness ratios equal to or less than the limiting values given in Table 1.1. These can be used for all the structural elements. • The stress distribution for these sections is rectangular.
3.	Semi-compact (Class 3)	<ul style="list-style-type: none"> • Cross sections, in which the extreme fiber in compression can reach yield stress (assuming an elastic distribution of stress), but cannot develop the plastic moment of resistance due to local buckling are referred to as semi-compact sections. • The yield stress reaches only in some parts of compression elements before buckling occurs. • It is not capable of reaching a fully plastic stress distribution. • These sections are used in elastic design. The stress distribution for such sections is triangular.
4.	Slender (Class 4)	<ul style="list-style-type: none"> • Cross sections, in which the elements buckle locally even before the attainment of yield stress are classed as slender sections. • These sections are used in cold-formed members and do not comply with the requirements of Table 1.1. • The effective section for design should be calculated by deducting width of compression plate element in excess of the semi-compact section limit.

1.5 MODES OF FAILURE IN BEAM

- (a) **Bending:** The gravity loading gives rise to bending of beam. This causes longitudinal stresses to be developed in the beam. As the bending moment increases, these flexural stresses increase further till they reach yield stress. At certain point, either the steel yields in tension and/or yields in compression. At this stage of loading, the beam section becomes plastic, fails by formation of a plastic hinge at the location of maximum moment being induced by the loading. Figure shows the various stages in a beam bending till failure.

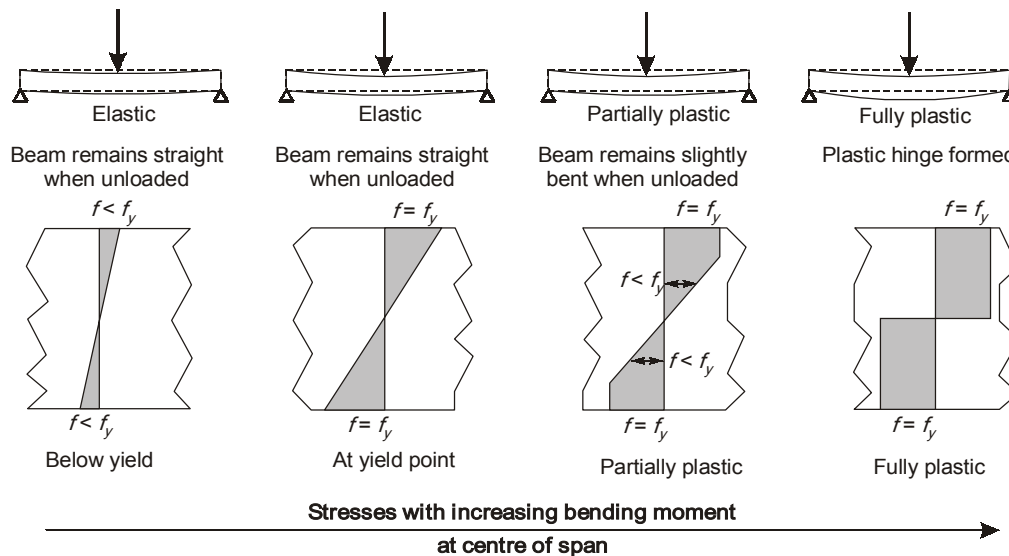

Fig. : Various stages of beam bending failure

- (b) **Local buckling:** During the bending process, if the compression flange or a part of the web subjected to compression is too thin to take any appreciable amount of compression then the plate may fail due to buckling (or rippling) even before the full plastic moment is reached.

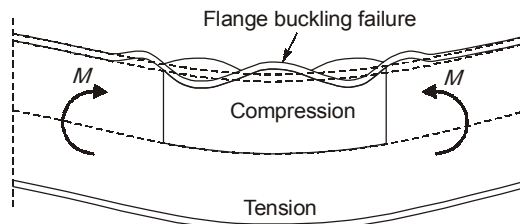

Fig.: Local flange buckling failure

- (c) **Shear:** Generally in portions near to the supports, very large shear exists. In this case the beam may fail in shear if the web is not of sufficient thickness. Formation of plastic hinges accompanies this process as shown in Fig. (a).
- (d) **Shear buckling:** During the shearing process, if the web is too thin then it is prone to get fail by buckling (or rippling) as shown in Fig. (b) & (c).

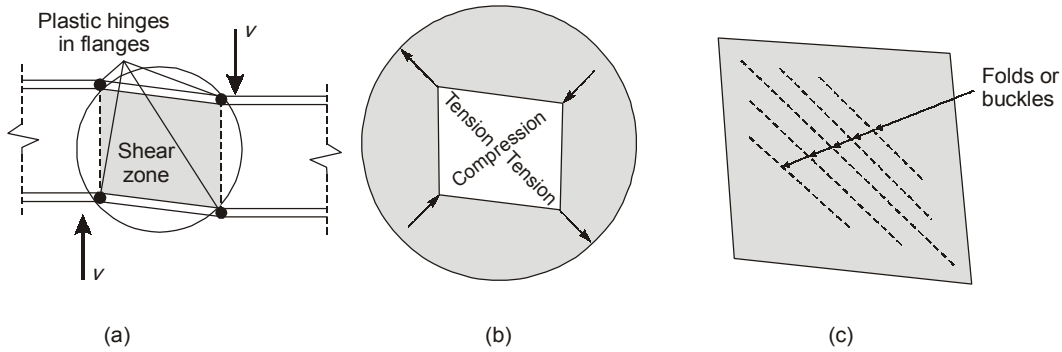

Fig.: Shear and shear buckling failure (a) shear failure, (b) shear buckling

(e) **Web crushing and buckling:** Because very high vertical stresses act on supports and at location of point loads, the beam web may get fail by crushing or buckling as shown in figure below.

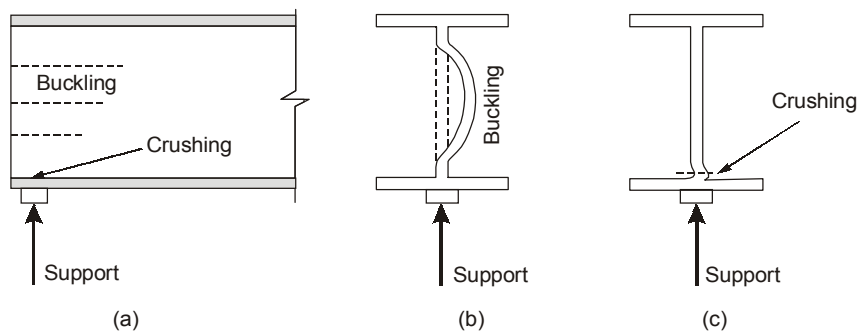

Fig.: Web buckling and web bearing failures

(f) **Lateral torsional buckling:** This type of failure occurs when the beam has high flexural stiffness in the vertical plane (i.e. in the direction of gravity) as compared to the horizontal plane. The beam has a tendency to deflect sideways.

- For example, a loaded cantilever as shown in figure below will deflect and twist in the sideways direction.

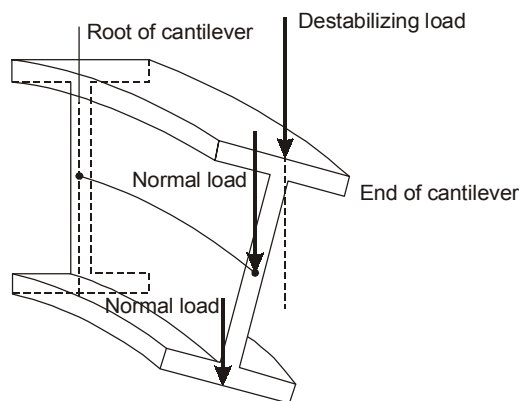

Fig. : Lateral torsional buckling of cantilever

When this beam is prevented from deflecting sideways by a floor/slab construction, the beam is torsionally restrained. It is essential to check the stability of beam in the lateral direction also. A nominal amount of torsional restraint is assumed to exist when web of the beam is connected through cleat angles, end plates etc. as shown in figure below.

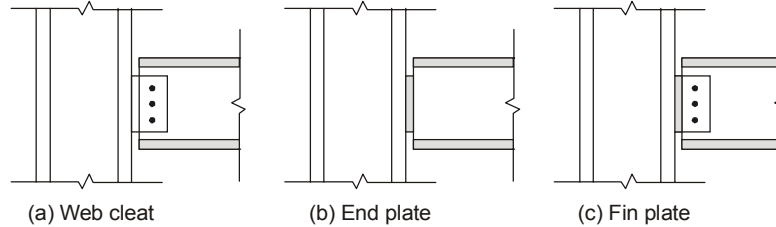

Fig. : Nominal torsional restraint at beam support supplied by
(a) Web cleats (b) End plate (c) Fin plate

(g) **Deflection:** It is quite practical that a beam may not get fail due to excessive deflection but on the other hand too much deflection can lead to discomfort to the occupants along with stripping off of flooring, finishes etc.

1.6 LOADS

- These are the forces that act on a structure.
- Loads are in fact **action** on a structure due to which a structure responds (i.e. **reaction**).
- This action acting on the structure may either be **direct action** or **indirect action**.

1.6.1 Direct Action

- These loads act directly on the structure and include dead loads, live loads, snow load, wind load etc.
- The intensity of these direct actions has been described by various codes/standards like in India, we have **IS 875 part I to V** for dead load, live load, wind load, snow load and various possible load combinations respectively and **IS 1893** for earthquake load.

1.6.2 Indirect Action

- Many a times loads act on the structure indirectly like due to temperature change, settlement, deformations etc.
- These indirect loads also need to be taken into account in the design process.

1.7 REACTIONS DUE TO ACTIONS ON STRUCTURE

- As per limit state method of design, the structure is required to satisfy the limit state of serviceability as well as limit state of collapse.
- A structure needs to be assessed for the effects of design loads (actions) including its individual members and connections.
- This analysis is done either by using elastic or the plastic method of analysis.

1.8 DESIGN OF STEEL STRUCTURES

- Errors and uncertainties get involved in precisely assessing the probable loads that will act on the structure and the structural behavior of the materials.

- The various structural design requirement criteria relate to corresponding limit states and thus the design of structure to comply with all the essential requirements may be called as limit state of design.
- There are two design criteria viz. the **strength design criteria** and the **stiffness design criteria**.

1.8.1 Strength Design Criteria

- These are related to possible modes of failure of a structure due to over loading and/or understrength conditions.
- These design criteria are concerned with yielding, buckling, fatigue, brittle fracture corrosion.
- The major design philosophies under these criteria are the **working stress method**, **ultimate load method** and the **limit state method**.

1.8.2 Stiffness Design Criteria

These design criteria are related to serviceability of the structure under working loads and are prominently concerned with ensuring that structure has sufficient stiffness that may otherwise lead to excessive deformations including deflections, distortion, sagging etc.

1.9 LIMIT STATE DESIGN

- In the limit state design of structures, all conditions are taken into account that makes the structure unfit for use.
- This limit state method of design considers all the relevant conditions pertaining to limit states of strength and serviceability.
- The strength limit states are based on load carrying capacity of the structure which includes buckling, fatigue, fracture etc. Serviceability limit states are based on performance of the structure under the actual application of service loads and includes deflection, vibration, corrosion, ponding etc.
- The loads at working conditions are factored by the use of partial safety factors for loads resulting in factored loads/design loads.
- The normal strength of the material is called as its ultimate capacity and the corresponding design strength of the material is obtained by dividing the ultimate capacity with the partial safety factor. Thus the member so designed must meet the basic criteria as

$$\text{Design action} \leq \text{Design strength}$$

**REMEMBER**

The section designed must satisfy the serviceability criteria over and above the strength criteria.

1.9.1 Advantages of Limit State Design

- (a) This method recognizes that design parameters are variants.
- (b) This method logically deals with the fact that there exists always a possibility of variations in loads and material properties.
- (c) This method gives different weightages to different loads and materials

1.9.2 Disadvantages of Limit State Design

There is a likelihood of design errors because of more complex theory which are not so in the working stress method of design.



IS 800 : 2007 is the design code for the structures which is based on limit state method of design however it still maintains the working stress design approach.

1.9.3 Design Load

- The design load in LSM of design is obtained by multiplying the working load (called as **characteristic load**) with a partial factor of safety and the resulting load is called as **factored load** or the **design load**. Different design loads (i.e. dead load, live load, wind load, earthquake load etc.) are then combined under the most severe but realistic conditions.

1.9.4 Design Strength

- The design strength of the material is obtained by dividing the characteristic strength of the material by a suitable partial factor of safety.
- The design strength of each material (and their connections) must be such that the most severe combination of design loads must not cause failure.
- It must also be ensured that the structure is stable against overturning, sway etc.

EXAMPLE : 1.1

Assuming Fe410 steel, classify the following sections:

(a) ISLB 350 @ 472 N/m

(b) ISHB 400 @ 806 N/m

(c) ISMB 450 @ 710 N/m

(d) ISA 80 × 80 × 8

Solution:

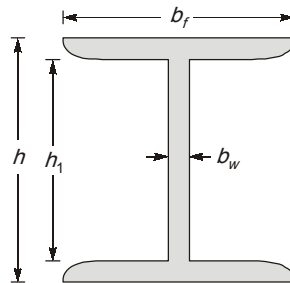

For Fe410

$$f_u = 410 \text{ N/mm}^2, f_y = 250 \text{ N/mm}^2$$

(a) ISLB 350 @ 472 N/m

$$b_f = 165 \text{ mm}, t_f = 11.4 \text{ mm}, h_1 = 288.3 \text{ mm}, t_w = 7.4 \text{ mm}$$

$$\epsilon = \sqrt{\frac{250}{f_y}} = \sqrt{\frac{250}{250}} = 1$$

$$\frac{b/2}{t_f} = \frac{165/2}{11.4} = 7.24 < 9.4\epsilon \text{ Thus flange is plastic.}$$