

SSC-JE

Staff Selection Commission

Junior Engineer

Electrical Engineering

Previous Years Solved Papers
(2007–2018)

Topicwise Objective Solved Questions

Also useful for

RRB-JE Mains

*various public sector examinations and
other competitive examinations*



MADE EASY
Publications

www.madeeasypublications.org



MADE EASY Publications

Corporate Office: 44-A/4, Kalu Sarai (Near Hauz Khas Metro Station), New Delhi-110016

E-mail: infomep@madeeasy.in

Contact: 011-45124660, 08860378007

Visit us at: www.madeeasypublications.org

SSC-Junior Engineer : Electrical Engineering Previous Year Solved Papers

Copyright © by MADE EASY Publications.

All rights are reserved. No part of this publication may be reproduced, stored in or introduced into a retrieval system, or transmitted in any form or by any means (electronic, mechanical, photo-copying, recording or otherwise), without the prior written permission of the above mentioned publisher of this book.

First Edition: 2016

Second Edition: 2018

Third Edition: 2019

MADE EASY PUBLICATIONS has taken due care in collecting the data and providing the solutions, before publishing this book. In spite of this, if any inaccuracy or printing error occurs then MADE EASY PUBLICATIONS owes no responsibility. MADE EASY PUBLICATIONS will be grateful if you could point out any such error. Your suggestions will be appreciated.

© All rights reserved by MADE EASY PUBLICATIONS. No part of this book may be reproduced or utilized in any form without the written permission from the publisher.

Preface

Staff Selection Commission-Junior Engineer has always been preferred by Engineers due to job stability. SSC-Junior Engineer examination is conducted every year. MADE EASY team has deeply analyzed the previous exam papers and observed that a good percentage of questions are repetitive in nature, therefore it is advisable to solve previous years papers before a candidate takes the exam.

The SSC JE texam is conducted in three stages as shown in table given below.



B. Singh (Ex. IES)

Papers	Subject	Maximum Marks	Duration
Stage 1: Paper-I : Objective type	(i) General Intelligence & Reasoning	50 Marks	2 hours
	(ii) General Awareness	50 Marks	
	(iii) General Engineering : Electrical	100 Marks	
Stage 2: Paper-II Conventional Type	General Engineering : Electrical	300 Marks	2 hours
Stage 3: Personal Interview		100 Marks	---

Note: In Paper-I, every question carry one mark and there is negative marking of $\frac{1}{4}$ marks for every wrong answer. Candidates shortlisted in Stage 1 are called for Stage 2. On the basis of combined score in Stage 1 and Stage 2, shortlisted candidates are called for Personal Interview.

In the second edition, the book has been thoroughly revised and Reasoning-Aptitude section is also added. MADE EASY has taken due care to provide complete solution with accuracy. Apart from Staff Selection Commission-Junior Engineer, this book is also useful for Public Sector Examinations and other competitive examinations for engineering graduates.

I have true desire to serve student community by providing good source of study and quality guidance. I hope this book will prove as an important tool to succeed in SSC-JE and other competitive exams. Any suggestion from the readers for improvement of this book is most welcome.

With Best Wishes

B. Singh

CMD, MADE EASY

Syllabus of Engineering Subjects

(For both Objective and Conventional Type Papers)

Electrical Engineering

Basic concepts: Concepts of resistance, inductance, capacitance, and various factors affecting them. Concepts of current, voltage, power, energy and their units.

Circuit law: Kirchhoff's law, Simple Circuit solution using network theorems.

Magnetic Circuit: Concepts of flux, mmf, reluctance, Different kinds of magnetic materials, Magnetic calculations for conductors of different configuration e.g. straight, circular, solenoidal, etc. Electromagnetic induction, self and mutual induction.

AC Fundamentals: Instantaneous, peak, R.M.S. and average values of alternating waves, Representation of sinusoidal wave form, simple series and parallel AC Circuits consisting of R, L and C, Resonance, Tank Circuit. Poly Phase system – star and delta connection, 3-phase power, DC and sinusoidal response of R-L and R-C circuit.

Measurement and Measuring Instruments: Measurement of power (1 phase and 3-phase, both active and re-active) and energy, 2 wattmeter method of 3-phase power measurement. Measurement of frequency and phase angle. Ammeter and voltmeter (both moving oil and moving iron type), extension of range wattmeter, Multimeters, Megger, Energy meter AC Bridges. Use of CRO, Signal Generator, CT, PT and their uses. Earth fault detection.

Electrical Machines: (a) D.C. Machine – Construction, Basic Principles of D.C. motors and generators, their characteristics, speed control and starting of D.C. Motors. Method of braking motor, Losses and efficiency of D.C. Machines. (b) 1 phase and 3 phase transformers – Construction, Principles of operation, equivalent circuit, voltage regulation, O.C. and S.C. Tests, Losses and efficiency. Effect of voltage, frequency and wave form on losses. Parallel operation of 1 phase /3 phase transformers. Auto transformers. (c) 3 phase induction motors, rotating magnetic field, principle of operation, equivalent circuit, torque-speed characteristics, starting and speed control of 3 phase induction motors. Methods of braking, effect of voltage and frequency variation on torque speed characteristics. Fractional Kilowatt Motors and Single Phase Induction Motors: Characteristics and applications.

Synchronous Machines: Generation of 3-phase e.m.f. armature reaction, voltage regulation, parallel operation of two alternators, synchronizing, control of active and reactive power. Starting and applications of synchronous motors.

Generation, Transmission and Distribution: Different types of power stations, Load factor, diversity factor, demand factor, cost of generation, inter-connection of power stations. Power factor improvement, various types of tariffs, types of faults, short circuit current for symmetrical faults. Switchgears – rating of circuit breakers, Principles of arc extinction by oil and air, H.R.C. Fuses, Protection against earth leakage/over current, etc. Buchholtz relay, Merz-Price system of protection of generators & transformers, protection of feeders and bus bars. Lightning arresters, various transmission and distribution system, comparison of conductor materials, efficiency of different system. Cable – Different type of cables, cable rating and derating factor.

Estimation and Costing: Estimation of lighting scheme, electric installation of machines and relevant IE rules. Earthing practices and IE Rules.

Utilization of Electrical Energy: Illumination, Electric heating, Electric welding, Electroplating, Electric drives and motors.

Basic Electronics: Working of various electronic devices e.g. P N Junction diodes, Transistors (NPN and PNP type), BJT and JFET. Simple circuits using these devices.



Contents

SSC-JE

Objective Solved Papers (Paper-I)

Electrical Engineering

Section-A (Technical)

Unit 1

Electrical Circuits 1-162

- 1.1 KCL & KVL, Phasor Calculations and Network Theorems..... 1
- 1.2 Transient and Steady State Response, Resonance & AC Circuits..... 104

Unit 2

Measurements & Instrumentation 163-225

- 2.1 Measurement of Voltage, Current, Resistance, Type of Instruments and Characteristic of Instrument..... 163
- 2.2 A.C. Bridges, CRO and Electronic Measurement, Measurement of Energy and Power, Transducers..... 193

Unit 3

Electrical Machines..... 226-372

- 3.1 DC Machines and Transformers, General Electrical Engineering 226
- 3.2 Three Phase Induction Machines, Synchronous Machines and Special Purpose Machines 311

Unit 4

Power Systems 373-436

- 4.1 Performance of Transmission Lines, Corona, Distribution Systems, Cables & Insulators..... 373
- 4.2 Economic Power Generation, Load Dispatch, Fault Analysis, Illuminisation and Protection..... 408

Unit 5

Analog & Digital Electronics 437-465

- 5.1 Semiconductor Physics & Devices, Diodes and their Biasing Circuits 437
- 5.2 BJT, FET and Their Biasing Circuits, Oscillators & Operational Amplifiers..... 453

Unit 6

Miscellaneous 466-486

- 6.1 General Engineering..... 466

Section-B (Non-Technical)

1. SSC-JE Paper-2007.....	487-490
2. SSC-JE Paper-2008.....	491-494
3. SSC-JE Paper-2009.....	495-497
4. SSC-JE Paper-2010.....	498-509
5. SSC-JE Paper-2011.....	510-520
6. SSC-JE Paper-2012.....	521-530
7. SSC-JE Paper-2013.....	531-540
8. SSC-JE Paper-25.05.2014(M).....	541-550
9. SSC-JE Paper-25.05.2014(E).....	551-560
10. SSC-JE Paper-2015.....	561-573
11. SSC-JE Paper-01.03.2017(M).....	574-585
12. SSC-JE Paper-01.03.2017(E).....	586-597
13. SSC-JE Paper-02.03.2017(M).....	598-607
14. SSC-JE Paper-02.03.2017(E).....	608-618
15. SSC-JE Paper-03.03.2017(M).....	619-628
16. SSC-JE Paper-03.03.2017(E).....	629-638
17. SSC-JE Paper-04.03.2017(M).....	639-649
18. SSC-JE Paper-04.03.2017(E).....	650-660
19. SSC-JE Paper-22.01.2018(M).....	661-673
20. SSC-JE Paper-22.01.2018(E).....	674-687
21. SSC-JE Paper-23.01.2018(M).....	688-700
22. SSC-JE Paper-23.01.2018(E).....	701-713
23. SSC-JE Paper-24.01.2018(M).....	714-726
24. SSC-JE Paper-24.01.2018(E).....	727-739
25. SSC-JE Paper-25.01.2018(M).....	740-753
26. SSC-JE Paper-25.01.2018(E).....	754-766
27. SSC-JE Paper-27.01.2018(M).....	767-779
28. SSC-JE Paper-27.01.2018(E).....	780-792
29. SSC-JE Paper-29.01.2018(M).....	793-804
30. SSC-JE Paper-29.01.2018(E).....	805-816



Section A : Technical

UNIT-I

1.1

Electrical Circuits

KCL & KVL, Phasor Calculations and Network Theorems

1. For the circuit shown below, voltage V_1 will be

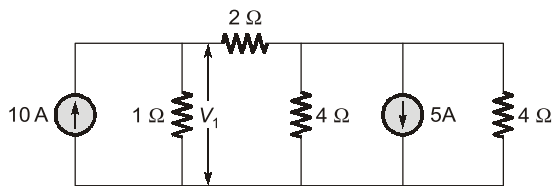

- (a) 2.64 V (b) 3.64 V
(c) 6.0 V (d) 9.1 V

[SSC-JE : 2007]

2. A circuit component that opposes the change in circuit voltage is

- (a) resistance (b) capacitance
(c) inductance (d) all the above

[SSC-JE : 2008]

3. The value of V in the circuit shown in the given figure is

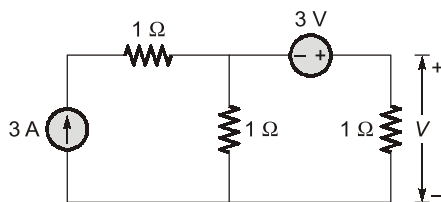

- (a) 1 V (b) 2 V
(c) 3 V (d) 4 V

[SSC-JE : 2008]

4. Two heaters rated at 1000 W, 250 V each are connected in series across a 250 V, 50 Hz AC mains. The total power drawn from the supply would be

- (a) 1000 watt (b) 500 watt
(c) 250 watt (d) 2000 watt

[SSC-JE : 2008]

5. Two coupled coils with $L_1 = L_2 = 0.6$ H have a coupling coefficient of $K = 0.8$. The turn ratio N_1/N_2 is

- (a) 4 (b) 2
(c) 1 (d) 0.5

[SSC-JE : 2008]

6. The efficiency for maximum power transfer to the load is

- (a) 25% (b) 50%
(c) 75% (d) 100%

[SSC-JE : 2008]

7. The value of current I flowing in the 1Ω resistor in the circuit shown in the figure below will be

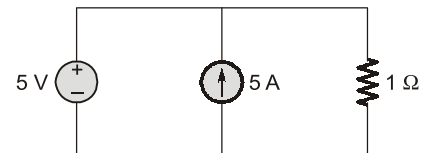

- (a) 10 A (b) 6 A
(c) 5 A (d) zero

[SSC-JE : 2009]

8. In the figure shown below, if we connect a source of 2 V, with internal resistance of 1Ω at AA' with positive terminal at A , then current through R is

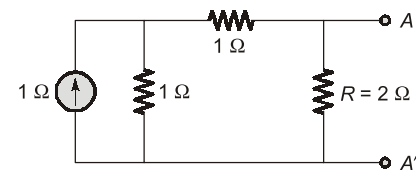

- (a) 2 A (b) 1.66 A
(c) 1 A (d) 0.625 A

[SSC-JE : 2009]

9. The curve representing Ohm's law is

- (a) Linear (b) Hyperbolic
(c) Parabolic (d) Triangular

[SSC-JE : 2009]

10. Specific resistance of a conductor depends upon

- (a) dimension of the conductor
(b) composition of conductor material
(c) resistance of the conductor

(d) both (a) and (b) [SSC-JE : 2009]

11. Superposition theorem is essentially based on the concept of

(a) Reciprocity (b) Linearity
(c) Duality (d) Non-linearity

[SSC-JE : 2009]

12. Two coupled coil with $L_1 = L_2 = 0.6$ H have a coupling coefficient of $K = 0.8$. The turn ratio

$$\frac{N_1}{N_2} \text{ is}$$

(a) 4 (b) 2
(c) 1 (d) 0.5

[SSC-JE : 2009]

13. A wire has a resistance 10Ω . It is stretched by one-tenth of the original length. Then its resistance will be

(a) 10Ω (b) 12.1Ω
(c) 9Ω (d) 11Ω

[SSC-JE : 2010]

14. The ratio of resistances of a 100 W, 220 V lamp to that of a 100 W, 110 V lamp will be equal to

(a) 4 (b) 2
(c) $\frac{1}{2}$ (d) $\frac{1}{4}$

[SSC-JE : 2010]

15. Time constant of the network shown in figure is

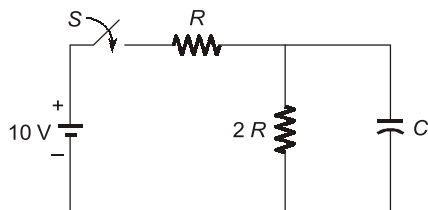

(a) $2RC$ (b) $3RC$
(c) $\frac{RC}{2}$ (d) $\frac{2RC}{3}$

[SSC-JE : 2010]

16. If four $10 \mu\text{F}$ capacitors are connected in parallel the net capacitance is

(a) $2.5 \mu\text{F}$ (b) $40 \mu\text{F}$
(c) $20 \mu\text{F}$ (d) $115 \mu\text{F}$

[SSC-JE : 2010]

17. If R_g in the circuit shown in figure is variable between 20Ω and 80Ω then maximum power transferred to the load R_L will be:

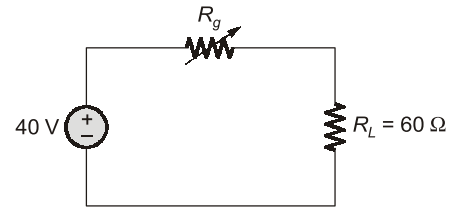

(a) 15 W (b) 13.33 W
(c) 6.67 W (d) 2.4 W

[SSC-JE : 2010]

18. Permeance is analogous to:

(a) Conductance (b) Reluctance
(c) Inductance (d) Resistance

[SSC-JE : 2010]

19. A voltage divider circuit and its Thevenin's equivalent are shown below. The values of V_{th} and R_{th} will be

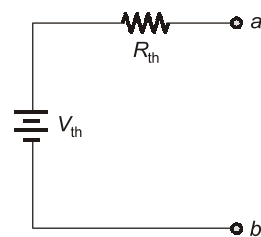
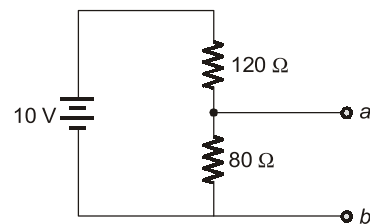

(a) 10 V, 80Ω (b) 4 V, 80Ω
(c) 4 V, 48Ω (d) 5 V, 50Ω

[SSC-JE : 2011]

20. The V-I relation for the network shown in the given box is $V = 4I - 9$. If now a resistor $R = 2 \Omega$ is connected across it, then the value of I will be

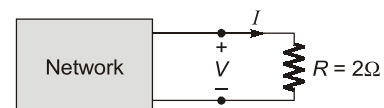

(a) -4.5 A (b) -1.5 A
(c) 1.5 A (d) 4.5 A

[SSC-JE : 2011]

21. Three resistance 5Ω each are connected in star. Values of equivalent delta resistances are

- (a) 1.5Ω each (b) 2.5Ω each
- (c) $5/3 \Omega$ each (d) 15Ω each

[SSC-JE : 2012]

22. A periodic train of rectangular pulses $x(t)$ with a time period of 25 seconds, has a pulse width of 9 second as shown in figure. The RMS value of the waveform is

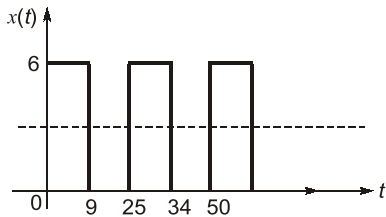

- (a) 10 V (b) $\sqrt{6}$ V
- (c) 3.6 V (d) 2.16 V

[SSC-JE : 2012]

23. The wires A and B of the same material but of different lengths L and $2L$ have the radius r and $2r$ respectively. The ratio of specific resistance will be
- (a) 1 : 4 (b) 1 : 8
 - (c) 1 : 1 (d) 1 : 2

[SSC-JE : 2012]

24. A non-sinusoidal periodic waveform is free from DC component, cosine components and even harmonics. The waveform has
- (a) half wave and odd function symmetry.
 - (b) half wave and even function symmetry.
 - (c) only odd function symmetry.
 - (d) only half wave symmetry.

[SSC-JE : 2012]

25. The equivalent resistance between terminals X and Y of the network shown is

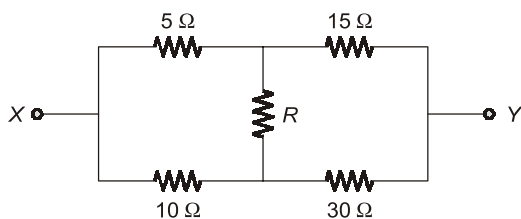

- (a) 8Ω (b) $\frac{100}{3} \Omega$
- (c) $\frac{40}{3} \Omega$ (d) $\frac{20}{9} \Omega$

[SSC-JE : 2012]

26. Application of Thevenin's theorem in a circuit results in
- (a) an ideal voltage source.
 - (b) an ideal current source.
 - (c) a current source and an impedance parallel.
 - (d) a voltage source and an impedance in series.

[SSC-JE : 2012]

27. A voltmeter when connected across a dc supply, reads 124 V. When a series combination of the voltmeter and an unknown resistance X is connected across the supply, the meter reads 4 V. If the resistance of the voltmeter is $50 \text{ k}\Omega$, the value of X is

- (a) $1550 \text{ k}\Omega$ (b) $1600 \text{ k}\Omega$
- (c) $1.6 \text{ k}\Omega$ (d) $1.5 \text{ M}\Omega$

[SSC-JE : 2013]

28. Two 2000Ω , 2 watt resistors are connected in parallel. Their combined resistance value and wattage rating are
- (a) 1000Ω , 2 watt (b) 1000Ω , 4 watt
 - (c) 2000Ω , 4 watt (d) 2000Ω , 2 watt

[SSC-JE : 2013]

29. We have three resistances each of value 1Ω , 2Ω and 3Ω . If all the three resistances are to be connected in a circuit, how many different values of equivalent resistance are possible?
- (a) Five (b) Six
 - (c) Seven (d) Eight

[SSC-JE : 2013]

30. An electric heater draws 1000 watts from a 250 V source. The power drawn from a 200 V source is
- (a) 800 W (b) 640 W
 - (c) 1000 W (d) 1562.5 W

[SSC-JE : 2013]

- 31.

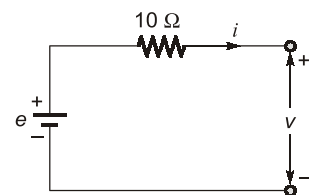

The voltage (v) vs current (i) curve of the circuit is shown below:

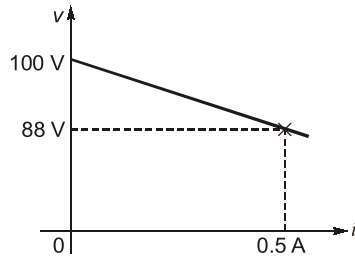

Internal resistance of the source 'e' is

- (a) 24Ω (b) 4Ω
(c) 10Ω (d) 14Ω

[SSC-JE : 2013]

32. A voltage source having an open-circuit voltage of 150 V and internal resistance of 75Ω , is equivalent to a current source of

- (a) 2 A in series with 75Ω
(b) 2 A in series with 37.5Ω
(c) 2 A in parallel with 75Ω
(d) 1 A in parallel with 150Ω

[SSC-JE : 2013]

33. Superposition theorem requires as many circuits to be solved as there are

- (a) nodes (b) sources
(c) loops (d) none of the above

[SSC-JE : 2013]

34. Application of Norton's theorem in a circuit results in

- (a) a current source and an impedance in parallel.
(b) a voltage source and an impedance in series.
(c) an ideal voltage source.
(d) an ideal current source.

[SSC-JE : 2013]

35. Value of the load impedance \bar{Z}_L for which the load consumes maximum power is

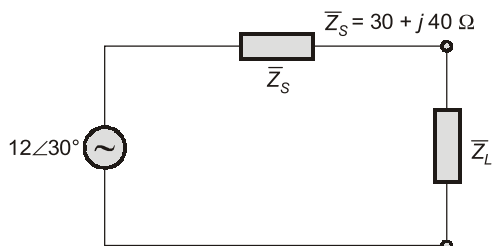

- (a) 50Ω at a power factor of 0.6 lead
(b) 50Ω at a power factor of 0.6 lag
(c) 30Ω at power factor of unity
(d) none of the above

[SSC-JE : 2013]

36. A stove element draws 15 A when connected to 230 V line. How long does it take to consume one unit of energy?

- (a) 3.45 h (b) 2.16 h
(c) 1.0 h (d) 0.29 h

[SSC-JE : 2014 (FN)]

37. Calculate the voltage drop across 14.5Ω resistance.

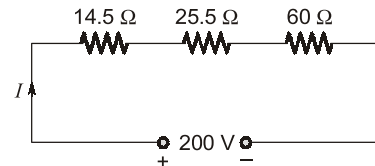

- (a) 14.5 V (b) 18 V
(c) 29 V (d) 30.5 V

[SSC-JE : 2014 (FN)]

38. For the network shown in the figure, the value of current in 8Ω resistor is

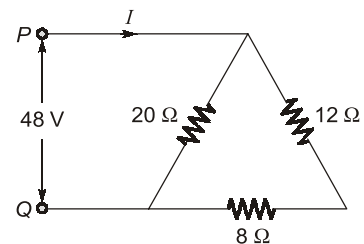

- (a) 4.8 A (b) 2.4 A
(c) 1.5 A (d) 1.2 A

[SSC-JE : 2014 (FN)]

39. The current drawn by a tungsten filament lamp is measured by an ammeter. The ammeter reading under steady state condition will be _____ the ammeter reading when the supply is switched on.

- (a) same as (b) less than
(c) greater than (d) double

[SSC-JE : 2014 (FN)]

40. Four resistance 2Ω , 4Ω , 5Ω , 20Ω are connected in parallel. Their combined resistance is

- (a) 1Ω (b) 2Ω
(c) 4Ω (d) 5Ω

[SSC-JE : 2014 (FN)]

41. In the figure, the value of R is

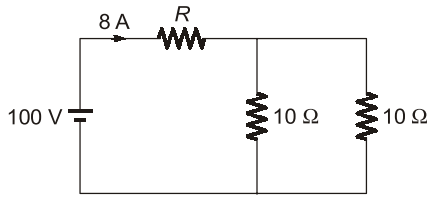

- (a) 2.5 Ω
- (b) 5.0 Ω
- (c) 7.5 Ω
- (d) 10.0 Ω

[SSC-JE : 2014 (FN)]

42. Power consumed in the given circuit is

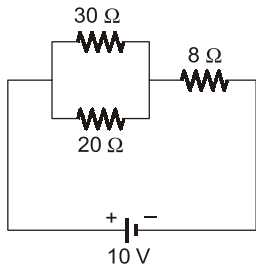

- (a) 100 watts
- (b) 5 watts
- (c) 20 watts
- (d) 40 watts

[SSC-JE : 2014 (FN)]

43. A 200 W, 200 V bulb and a 100 W, 200 V bulb are connected in series and the voltage of 400 V is applied across the series connected bulbs. Under this condition

- (a) 100 W bulb will be brighter than 200 W bulb.
- (b) 200 W bulb will be brighter than 100 W bulb.
- (c) Both the bulbs will have equal brightness.
- (d) Both the bulbs will be darker than when they are connected across rated voltage.

[SSC-JE : 2014 (FN)]

44. In the network shown, if one of the 4 Ω resistances is disconnected, when the circuit is active, the current flowing now will

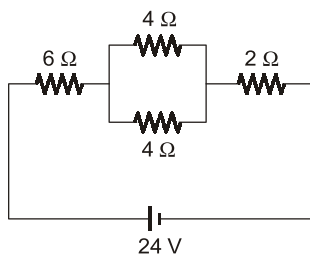

- (a) increase very much
- (b) decrease
- (c) be zero
- (d) increase very slightly

[SSC-JE : 2014 (FN)]

45. For the circuit shown in figure, when $V_s = 0$, $I = 3A$. When $V_s = 200 V$, what will be the value of I ?

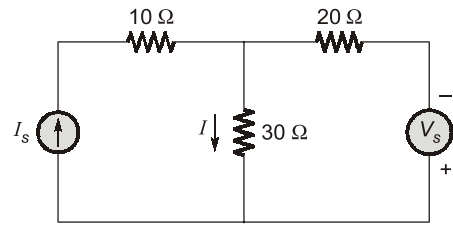

- (a) -4 A
- (b) -1 A
- (c) 1 A
- (d) 7 A

[SSC-JE : 2014 (FN)]

46. The current I in the circuit shown in the figure is

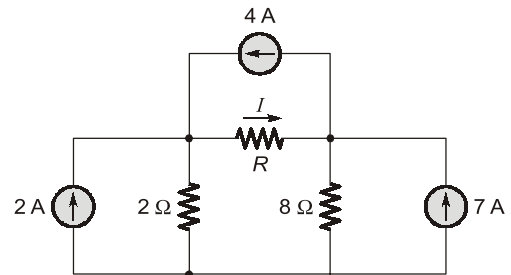

- (a) -3.67 A
- (b) -1 A
- (c) 4 A
- (d) 6 A

[SSC-JE : 2014 (FN)]

47. Two wires A and B have the same cross-section and are made of the same material. $R_A = 600 \Omega$ and $R_B = 100 \Omega$. The number of times A is longer than B is:

- (a) 5
- (b) 6
- (c) 2
- (d) 4

[SSC-JE : 2014 (AN)]

48. Two 100 W, 200 V lamps are connected in series across a 200 V supply. The total power consumed by each lamp in watts will be

- (a) 200
- (b) 25
- (c) 50
- (d) 100

[SSC-JE : 2014 (AN)]

49. A terminal where three or more branches meet is known as:

- (a) mesh
- (b) node
- (c) terminus
- (d) loop

[SSC-JE : 2014 (AN)]

50. Find the current through $5\ \Omega$ resistor:

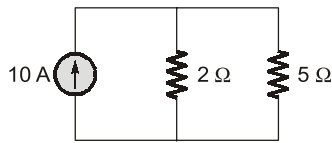

- (a) 3.5 A (b) 7.15 A
(c) 5 A (d) 2.85 A

[SSC-JE : 2014 (AN)]

51. Total capacitance between the point L and M in figure is

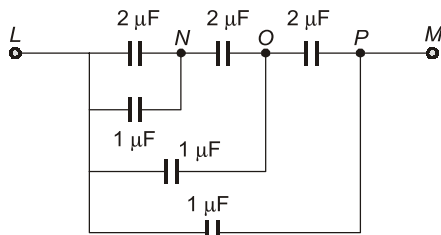

- (a) $4.05\ \mu\text{F}$ (b) $1.45\ \mu\text{F}$
(c) $1.85\ \mu\text{F}$ (d) $2.05\ \mu\text{F}$

[SSC-JE : 2014 (AN)]

52. The mutual inductance between two unity coupled coils of 9 H and 4 H will be:

- (a) 36 H (b) 2.2 H
(c) 6 H (d) 13 H

[SSC-JE : 2014 (AN)]

53. Determine the voltage at point C shown below with respect to ground:

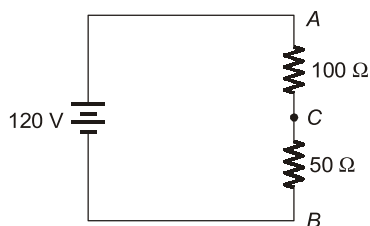

- (a) 80 V (b) 120 V
(c) 40 V (d) 70 V

[SSC-JE : 2014 (AN)]

54. Three resistors, each of ' R ' Ω are connected in star. What is the value of equivalent delta connected resistors?

- (a) $3R\ \Omega$ (b) $\frac{R}{2}\ \Omega$
(c) $2R\ \Omega$ (d) $\frac{R}{3}\ \Omega$

[SSC-JE : 2014 (AN)]

55. Two electric bulbs have tungsten filament of same thickness. If one of them gives 60 W, and the other gives 100 W, then

- (a) 60 W and 100 W lamp filaments have equal length.
(b) 60 W lamp filament has shorter length.
(c) 100 W lamp filament has longer length.
(d) 60 W lamp filament has longer length.

[SSC-JE : 2014 (AN)]

56. Find R_3 for the circuit shown in figure:

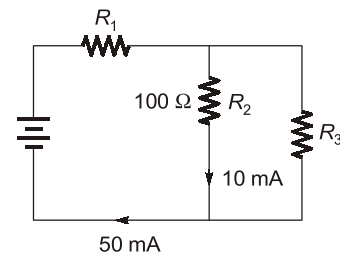

- (a) 25 mega ohm (b) 25 milli ohm
(c) 25 ohm (d) 25 kilo ohm

[SSC-JE : 2014 (AN)]

57. An ideal voltage source should have

- (a) infinite source resistance
(b) large value of emf
(c) small value of emf
(d) zero source resistance

[SSC-JE : 2014 (AN)]

58. For the linear circuit shown in figure, when $R = \infty$, $V = 20\ \text{V}$;
when $R = 0$, $I = 4\ \text{A}$;
when $R = 5\ \Omega$, the current I is

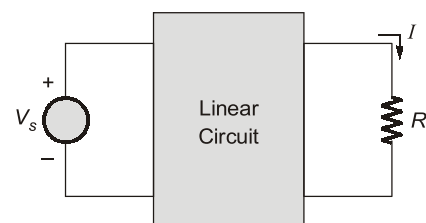

- (a) 1 A (b) 2 A
(c) 3 A (d) 4 A

[SSC-JE : 2014 (FN)]

59. In the network shown in the figure, the value of R_L such that maximum possible power will be transferred to R_L is

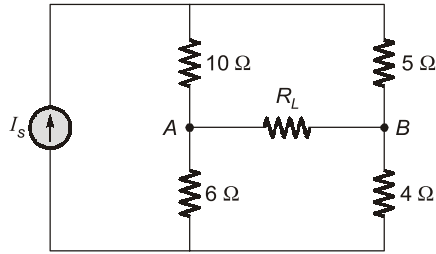

- (a) 5.76 Ω (b) 6.0 Ω
 (c) 10.0 Ω (d) 15.0 Ω
 [SSC-JE : 2014 (FN)]

60. The circuit shown in the given figure is equivalent to a load of

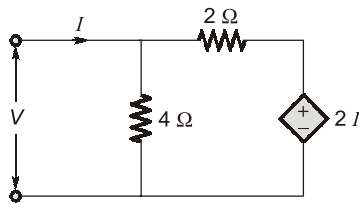

- (a) 4/3 Ω (b) 8/3 Ω
 (c) 4 Ω (d) 2 Ω
 [SSC-JE : 2014 (FN)]

61. Find R_{AB} for the circuit shown in figure.

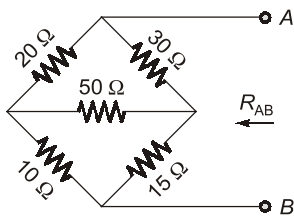

- (a) 18 Ω (b) 30 Ω
 (c) 45 Ω (d) 68 Ω
 [SSC-JE : 2014 (FN)]

62. Calculate the total susceptance of the circuit shown in figure.

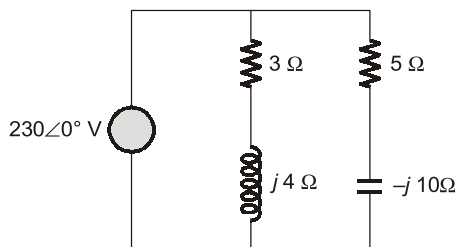

- (a) 6.67 S (b) 1.87 S
 (c) 0.16 S (d) 0.08 S
 [SSC-JE : 2014 (FN)]

63. The efficiency normally obtained in a circuit under the conditions of maximum power transfer is
 (a) 100% (b) 25%
 (c) 50% (d) 75%
 [SSC-JE : 2014 (AN)]

64. Superposition theorem can be applied only to
 (a) bilateral networks
 (b) linear networks
 (c) nonlinear networks
 (d) linear bilateral networks
 [SSC-JE : 2014 (AN)]

65. Using Millman's theorem, find the current through the load resistance R_L of 3 Ω resistance shown below:

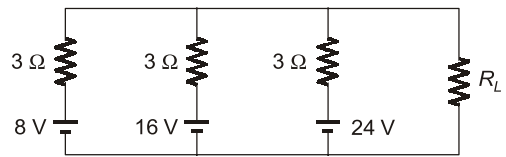

- (a) 12 A (b) 4 A
 (c) 6 A (d) 8 A
 [SSC-JE : 2014 (AN)]

66. Thevenin's equivalent voltage and resistance between the terminal A and B for network of given figure is:

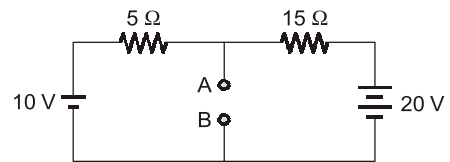

- (a) 2.5 V, 12.5 Ω (b) 2.5 V, 3.75 Ω
 (c) 12.5 V, 3.75 Ω (d) 12.5 V, 2.5 Ω
 [SSC-JE : 2014 (AN)]

67. The voltage across the 1 kΩ resistor of the network shown in the given figure is:

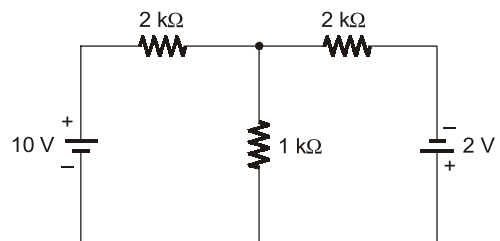

- (a) 2 V (b) 4 V
 (c) 6 V (d) 1 V
 [SSC-JE : 2015]

Answers KCL & KVL, Phasor Calculations and Network Theorems

1. (c) 2. (b) 3. (c) 4. (b) 5. (c) 6. (b) 7. (c) 8. (d) 9. (a)
10. (b) 11. (b) 12. (c) 13. (b) 14. (a) 15. (d) 16. (b) 17. (a) 18. (a)
19. (c) 20. (d) 21. (d) 22. (c) 23. (c) 24. (a) 25. (c) 26. (d) 27. (d)
28. (b) 29. (d) 30. (b) 31. (d) 32. (c) 33. (b) 34. (a) 35. (a) 36. (d)
37. (c) 38. (b) 39. (b) 40. (a) 41. (c) 42. (b) 43. (a) 44. (b) 45. (b)
46. (*) 47. (b) 48. (b) 49. (b) 50. (d) 51. (d) 52. (c) 53. (c) 54. (a)
55. (d) 56. (c) 57. (d) 58. (b) 59. (b) 60. (b) 61. (a) 62. (d) 63. (c)
64. (d) 65. (b) 66. (c) 67. (a) 68. (b) 69. (b) 70. (d) 71. (c) 72. (c)
73. (a) 74. (b) 75. (b) 76. (c) 77. (c) 78. (b) 79. (d) 80. (c) 81. (b)
82. (a) 83. (b) 84. (c) 85. (a) 86. (c) 87. (c) 88. (d) 89. (a) 90. (b)
91. (b) 92. (b) 93. (c) 94. (a) 95. (d) 96. (c) 97. (d) 98. (b) 99. (a)
100. (b) 101. (a) 102. (c) 103. (b) 104. (a) 105. (c) 106. (c) 107. (c) 108. (b)
109. (a) 110. (b) 111. (a) 112. (d) 113. (d) 114. (a) 115. (b) 116. (c) 117. (a)
118. (b) 119. (c) 120. (c) 121. (b) 122. (b) 123. (b) 124. (b) 125. (a) 126. (c)
127. (c) 128. (d) 129. (d) 130. (a) 131. (*) 132. (c) 133. (a) 134. (b) 135. (d)
136. (b) 137. (c) 138. (d) 139. (c) 140. (c) 141. (b) 142. (d) 143. (d) 144. (a)
145. (a) 146. (c) 147. (d) 148. (b) 149. (*) 150. (c) 151. (d) 152. (d) 153. (d)
154. (d) 155. (c) 156. (a) 157. (b) 158. (b) 159. (a) 160. (c) 161. (b) 162. (b)
163. (c) 164. (c) 165. (d) 166. (a) 167. (b) 168. (a) 169. (c) 170. (a) 171. (a)
172. (c) 173. (a) 174. (b) 175. (c) 176. (d) 177. (d) 178. (c) 179. (c) 180. (a)
181. (a) 182. (d) 183. (b) 184. (a) 185. (a) 186. (c) 187. (a) 188. (a) 189. (c)
190. (c) 191. (c) 192. (d) 193. (b) 194. (d) 195. (d) 196. (c) 197. (c) 198. (a)
199. (c) 200. (b) 201. (d) 202. (c) 203. (a) 204. (a) 205. (d) 206. (d) 207. (d)
208. (c) 209. (c) 210. (b) 211. (a) 212. (a) 213. (a) 214. (b) 215. (d) 216. (d)
217. (b) 218. (a) 219. (c) 220. (a) 221. (c) 222. (b) 223. (b) 224. (b) 225. (c)
226. (*) 227. (a) 228. (c) 229. (d) 230. (a) 231. (c) 232. (d) 233. (a) 234. (b)
235. (c) 236. (b) 237. (d) 238. (c) 239. (c) 240. (a) 241. (c) 242. (b) 243. (d)
244. (a) 245. (b) 246. (d) 247. (b) 248. (d) 249. (a) 250. (b) 251. (a) 252. (b)
253. (d) 254. (c) 255. (c) 256. (a) 257. (b) 258. (b) 259. (a) 260. (a) 261. (c)
262. (d) 263. (b) 264. (c) 265. (d) 266. (a) 267. (a) 268. (b) 269. (b) 270. (b)

Explanations KCL & KVL, Phasor Calculations and Network Theorems

1. (c)

Let us mark the current directions as shown in figure below.

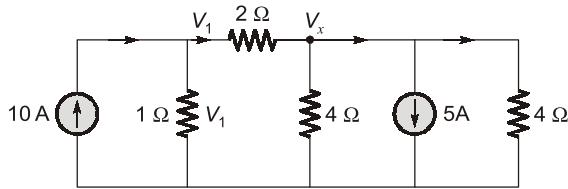

Applying KCL at points of voltages V_1 and V_x , we have:

$$10 = \frac{V_1}{1} + \frac{V_1 - V_x}{2}$$

or, $V_1 - V_x + 2V_1 = 20$
 $3V_1 - V_x = 20 \quad \dots(i)$

At node,

$$V_x, \quad \frac{V_1 - V_x}{2} = \frac{V_x}{4} + 5 + \frac{V_x}{4}$$

or, $2V_1 - 4V_x = 20 \quad \dots(ii)$

Solving equations (i) and (ii),

$$V_1 = 6 \text{ Volts}$$

Shortcut:

By source transformation techniques:

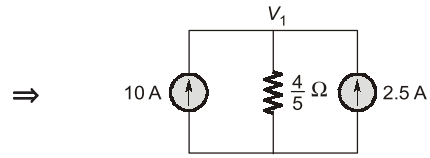
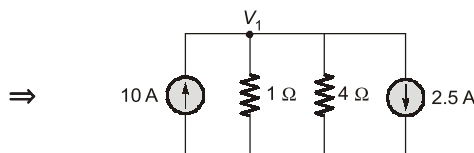
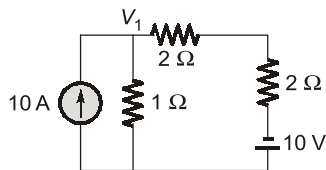
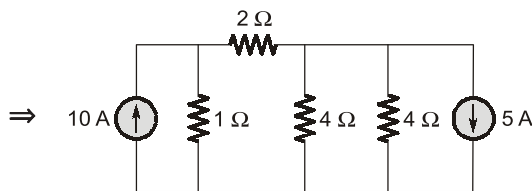
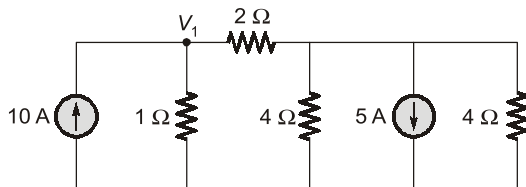

So, $V_1 = 7.5 \times \frac{4}{5} \text{ V} = 6 \text{ V}$

2. (b)

Capacitor opposes the sudden change in voltage.

i.e. it opposes the dv/dt across it. It is used to maintain the voltage between two points.

3. (c)

Let the node voltage be V_x .

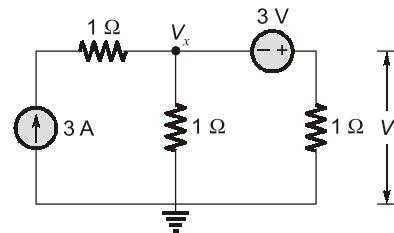

Applying KCL at the given node, we have:

$$\frac{V_x}{1} + \frac{V_x + 3}{1} = 3$$

or $V_x = 0 \text{ V}$
 $\therefore V_x + 3 = V$
 or $V = 3 \text{ V}$

4. (b)

The heaters of 1000 W, 250 V will have the resistance of

$$R = \frac{V^2}{P} = \frac{(250)^2}{1000} = 62.5 \Omega$$

So, equivalent circuit will be as shown below.

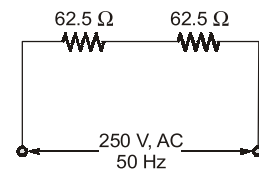

$\therefore R_{eq} = 125 \Omega$

$\therefore P = \frac{V^2}{R_{eq}} = \frac{(250)^2}{125} = 500 \text{ W}$

5. (c)

Since for a coil/inductor, the inductance

$$L = \frac{N^2}{\text{Reluctance}} = \frac{N^2}{l/\mu_0 A}$$

(for air core)

or, $L = \frac{\mu_0 N^2 A}{l}$ or $L \propto N^2$

$$\therefore \frac{L_1}{L_2} = \left(\frac{N_1}{N_2}\right)^2$$

$$\therefore \frac{L_1}{L_2} = \frac{0.6}{0.6} = 1 \Rightarrow \frac{N_1}{N_2} = 1$$

6. (b)

At maximum power transfer condition, the load resistance = Source resistance

i.e., $R_L = R_S$ (in dc circuit)

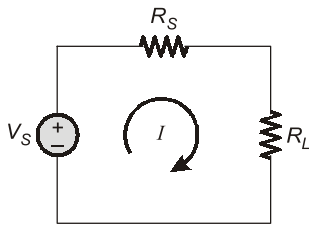

From above circuit,

$$I = \frac{V_s}{R_s + R_L}$$

$$\therefore \text{Load power} = I^2 R_L = \text{Output power}$$

$$\text{loss} = I^2 R_s$$

$$\therefore \eta = \frac{\text{output}}{\text{input}} = \frac{\text{output}}{\text{output} + \text{loss}}$$

$$\therefore \eta = \frac{I^2 R_L}{I^2 R_L + I^2 R_s}$$

$$\therefore R_L = R_s$$

$$\therefore \eta = \frac{I^2 R_L}{2I^2 R_L} = \frac{1}{2} \quad \text{or} \quad \eta = 50\%$$

7. (c)

From ohm's law, if we know the voltage across a resistor, then we can determine the current

through resistor R as $I = \frac{V}{R}$.

Here, $V = 5 \text{ V (constant)}$

So, $I = \frac{5}{1} = 5 \text{ A}$

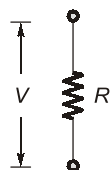

Note: The voltage across any current source is purely arbitrarily. The voltage across it depends purely upon the voltage source connected in parallel across it. Hence, in present case voltage across the current source = 5 V.

8. (d)

According to question,

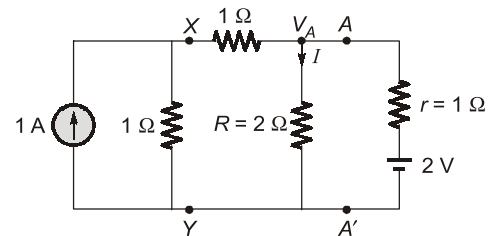

Here, I is to be determined.

If we can find the value of V_A then $I = \frac{V_A}{R} \text{ A}$.

Now converting current source to voltage source

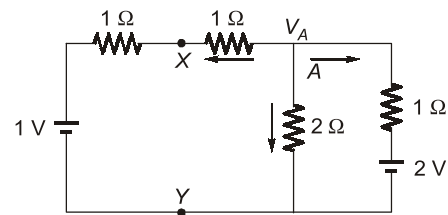

Applying nodal analysis at node V_A ,

$$\frac{V_A - 1}{2} + \frac{V_A}{2} + \frac{V_A - 2}{1} = 0$$

$$\Rightarrow 2V_A = 2.5$$

$$\Rightarrow V_A = 1.25 \text{ V}$$

or, $I = \frac{1.25}{2} = 0.625 \text{ A}$

9. (a)

Ohm's law is $I = \frac{V}{R}$ or $I \propto V$.

\therefore The relation between V & I is linear (If $1/R$ is a constant).

10. (b)

Specific resistance ' ρ ' of a material is a property of that material which depends only upon temperature and the composition of material. However, the resistance depends on length, area, temperature.

Resistance, $R \propto \frac{l}{A}$

or, $R = \frac{\rho l}{A}$ (ρ = specific resistance)

where, 'ρ' is constant for constant temperature.

11. (b)

Superposition theorem is used in the linear circuits having more than one independent voltage or current sources.

12. (c)

The inductance of a coil is

$$L = \frac{N^2 \mu_0 A}{l} \quad (\text{For air core})$$

$$\therefore L \propto N^2$$

or, $\frac{L_1}{L_2} = \frac{N_1^2}{N_2^2}$

$$\therefore \frac{N_1}{N_2} = \sqrt{\frac{L_1}{L_2}} = \sqrt{\frac{0.6}{0.6}} = 1$$

13. (b)

As the wire is stretched, the area will decrease and the length will increase but the net conductor volume will remain same.

Since, volumes are equal, therefore

$$A_1 l_1 = A_2 l_2 \quad \dots(i)$$

If $l_1 = l$, then

$$l_2 = l + \frac{1}{10} \text{th of } l = l + \frac{l}{10}$$

so, $l_2 = \frac{11l}{10}$

$$\therefore \frac{l_1}{l_2} = \frac{l}{\frac{11l}{10}} = \frac{10}{11}$$

Now from equation (i),

$$\frac{l_1}{l_2} = \frac{A_2}{A_1} = \frac{10}{11}$$

Given, $R_1 = 10 \Omega$

Now, from $R = \frac{\rho l}{A}$ we have,

$$\frac{R_1}{R_2} = \frac{l_1}{l_2} \times \frac{A_2}{A_1}$$

or, $\frac{R_1}{R_2} = \frac{100}{121}$

or, $R_2 = \frac{121 R_1}{100} = \frac{121 \times 10}{100} = 12.1 \Omega$

14. (a)

Given: $P_1 = 100 \text{ W}, V_1 = 220 \text{ V}$

$P_2 = 100 \text{ W}, V_2 = 110 \text{ V}$

Now, $R_1 = \frac{V_1^2}{P_1} = \frac{(220)^2}{100} = 484 \Omega$

Also, $R_2 = \frac{V_2^2}{P_2} = \frac{(110)^2}{100} = 121 \Omega$

$$\therefore \frac{R_1}{R_2} = \frac{484}{121} = \frac{4}{1} = 4$$

15. (d)

For finding R_{eq} , voltage source is short circuited and R_{eq} is found across 'C'.

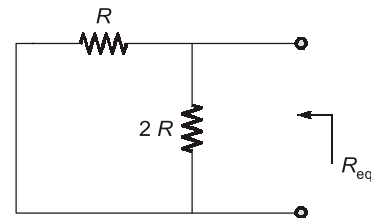

$$R_{eq} = \frac{2R \times R}{3R} = \frac{2}{3}R$$

$$\therefore T = \text{Time constant} = R_{eq} C = \frac{2}{3}RC$$

16. (b)

The equivalent capacitance for parallel connection is equal to sum of the individual capacitance.

$$\therefore C_{eq} = C_1 + C_2 + C_3 + C_4$$

$$C_{eq} = 40 \mu\text{F} \quad (\text{for parallel connection})$$

Note: For series connection,

$$\frac{1}{C_{eq}} = \frac{1}{C_1} + \frac{1}{C_2} + \frac{1}{C_3} + \frac{1}{C_4}$$

17. (a)

Maximum power transfer theorem is valid when the load resistance R_L is variable but here R_L is constant.

Then, for a constant resistance R_L , the power

$$P = \frac{V_L^2}{R_L} \text{ will be maximum when } V_L \text{ will be}$$

maximum (since R_L is constant).

Now, V_L will be maximum when R_g drop is minimum i.e. R_g is minimum.

So, $R_{g\min} = 20 \Omega$ if $20 \leq R_g \leq 80 \Omega$

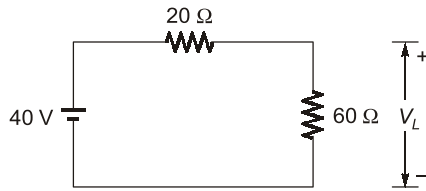

$$\text{So, } V_L = \frac{40 \times 60}{80} = 30 \text{ V}$$

$$P_L = \frac{30 \times 30}{60} = 15 \text{ W}$$

18. (a)

Magnetic properties **Electrical properties**

MMF \approx EMF

Flux \approx Current

Permeance \approx Conductance

Reluctance \approx Resistance

19. (c)

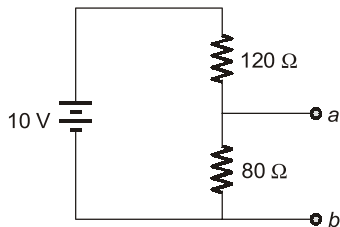

$$V_{Th} = V_{ab}$$

= Open circuit voltage across ab

$$= \frac{80}{200} \times 10 \text{ V} = 4 \text{ V}$$

Also, $R_{Th} = 80 \Omega \parallel 120 \Omega$

$$= \frac{80 \times 120}{200} = 48 \Omega$$

(For finding R_{Th} 10 V voltage source short circuited)

20. (d)

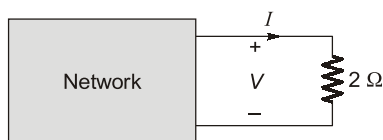

$$V = 4I - 9 \text{ (given)} \quad \dots(i)$$

Also, $V = 2I \quad \dots(ii)$

From equation (i) and (ii), we have

$$2I = 4I - 9$$

$$\Rightarrow I = 4.5 \text{ A}$$

21. (d)

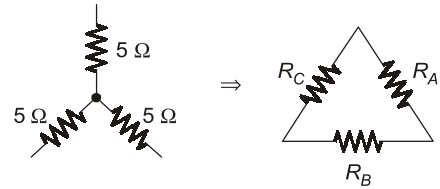

$$R_A = \frac{5 \times 5 + 5 \times 5 + 5 \times 5}{5}$$

$$= \frac{75}{5} = 15 \Omega$$

As all resistance in star network are equal, therefore,

$$R_A = R_B = R_C = 15 \Omega$$

22. (c)

$$V_{Rms} = \sqrt{\frac{1}{T} \int_0^T x^2(t) dt} = \sqrt{\frac{1}{25} \int_0^{25} x^2(t) dt}$$

$$= \frac{1}{5} \sqrt{\int_0^9 (6)^2 dt + \int_9^{25} (0)^2 dt} = \frac{1}{5} \sqrt{(36t)_0^9 + 0}$$

$$= \frac{1}{5} \sqrt{(36 \times 9)} = \frac{1}{5} \times 6 \times 3 = 3.6 \text{ V}$$

23. (c)

As the wires are of same material, therefore specific resistance of both the wires A and B will be same (Because specific resistance depends only on type of materials).

24. (a)

As DC and cosine components are absent, therefore it is an odd signal.

As even harmonics are absent, therefore it has half wave symmetry.

25. (c)

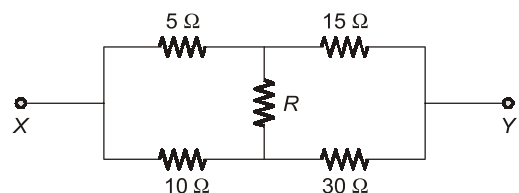

Above circuit is a balanced Wheatstone bridge, Hence, no current flows through the resistance R since arms ratio is constant.

i.e. $\frac{5}{10} = \frac{15}{30} = \frac{1}{2} = \text{constant}$
 $\therefore R_{xy} = (5 + 15) \parallel (10 + 30) = 20 \parallel 40$
 $= \frac{20 \times 40}{20 + 40} = \frac{40}{3} \Omega$

26. (d)

Thevenin's theorem results in simplification of circuit containing a voltage source and an impedance connected in series.

27. (d)

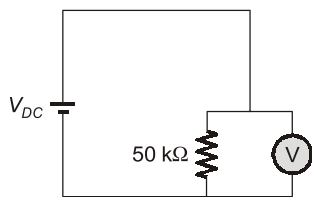

As voltmeter reads 124 V across DC supply.
Hence, $V_{DC} = 124 \text{ V}$
Now, a resistor is connected in series. Let the current through the circuit be 'I'.

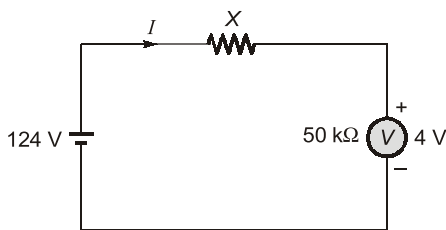

Then, $124 - 4 = IX$
or, $120 = IX$ or $X = \frac{120}{I}$
Also, $I = \frac{4}{50 \text{ k}}$
 $\therefore X = \frac{120 \times 50 \text{ k}}{4}$
 $\Rightarrow X = 1500 \text{ k}\Omega = 1.5 \text{ M}\Omega$

28. (b)

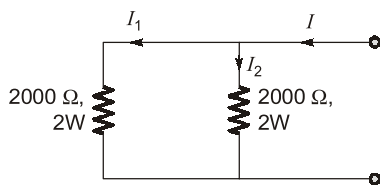

Equivalent resistance,
 $R_{eq} = R_1 \parallel R_2$

$= 2000 \parallel 2000 = 1000 \Omega$
Also, $P_1 = 2 \text{ W} = I_1^2 \cdot 2000$
or, $I_1^2 = \frac{1}{1000}$
Since, applied voltage is same across both resistors, therefore

$I_1 = \frac{1}{\sqrt{1000}} \text{ A} = I_2$
 $\therefore I = I_1 + I_2 = \frac{2}{\sqrt{1000}} \text{ A}$
 $\therefore P = I^2 \cdot R_{eq} = \frac{4}{1000} \times 1000 = 4 \text{ W}$

29. (d)

In eight ways, we can connect the given three resistances as shown below:

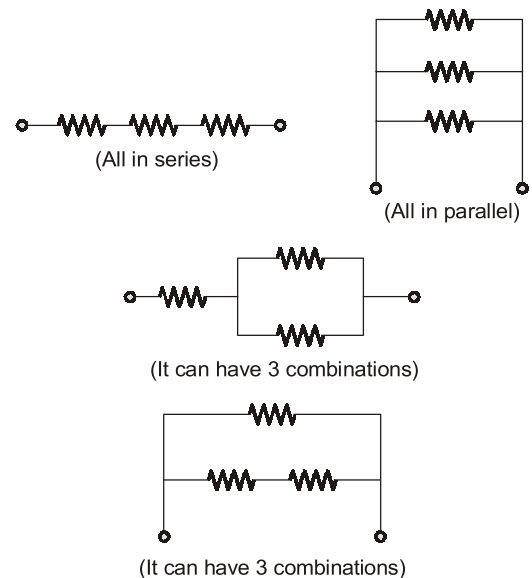

30. (b)

Given, $V = 250 \text{ V}$
and power drawn,
 $P = 1000 \text{ W} = \frac{(250)^2}{R}$
or, $R = \frac{250 \times 250}{1000} = \frac{125}{2} = 62.5 \Omega$
 $= \text{Heater resistance}$
Now, $V = 200 \text{ Volt}$
 \therefore Power drawn from 200 V voltage source
 $P = \frac{V^2}{R} = \frac{200 \times 200}{62.5} = 640 \text{ W}$

31. (d)

Let internal resistance of source is r .

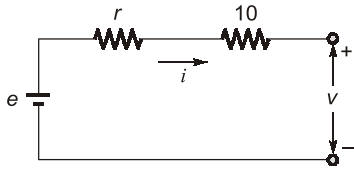

Applying KVL, we get

$$e - i(10 + r) = v \quad \dots(i)$$

Now, from given curve when $i = 0$,

$$e = v = 100 \text{ V}$$

Putting this value in equation (i), we have

$$100 - i(10 + r) = v \quad \dots(ii)$$

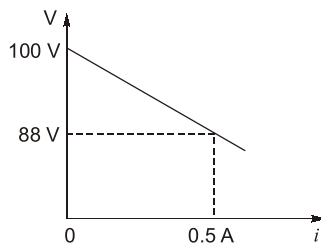

From graph, $v - i$ relation is

$$v = -24i + 100 \quad \dots(iii)$$

From equation (ii) and (iii), we have

$$24 = 10 + r$$

or,

$$r = 14 \Omega$$

= Internal resistance of source 'e'

32. (c)

Given, $V_{OC} = 150$
 $R_i = 75 \Omega$

$$I_{SC} = \frac{V_{OC}}{R_i} = \frac{150}{75} = 2 \text{ A}$$

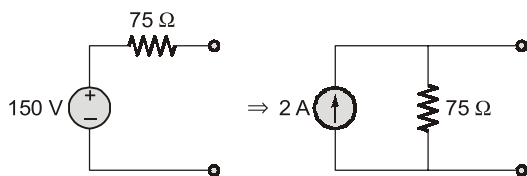

(Voltage source to current source transformation)

33. (b)

Superposition theorem requires as many circuits to be solved as there are sources.

It considers one source at a time and deactivates other sources.

34. (a)

Norton's theorem application in a circuit results in a current source and an impedance in parallel as shown below:

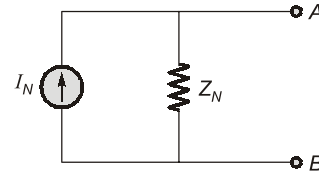
**35. (a)**

Value of Z_L for maximum power transfer is

$$Z_L = Z_S^*$$

Here, $Z_S = 30 + j40 \Omega$

$$\therefore Z_L = 30 - j40 \Omega$$

Hence, $|Z_L| = \sqrt{(30)^2 + (40)^2} = 50 \Omega$

$$\text{Power factor} = \frac{R}{|Z_L|} = \frac{30}{50} = 0.6$$

As load reactance is capacitive in nature (negative imaginary part), therefore, power factor is leading.

Hence, $|Z_L| = 50 \Omega$ at power factor of 0.6 lead.

36. (d)

Given, $I = 15 \text{ A}$

$$V = 230 \text{ V}$$

$$P = VI = 230 \times 15$$

$$(\cos \phi = 1 \text{ as stove element})$$

$$= 3450 \text{ W}$$

Now, energy,

$$E = P \times t$$

Unit of energy is kW-hour,

$$1000 \text{ Whr} = 3450 \text{ W} \times t$$

or, $t = \frac{1000}{3450} \text{ hr} \approx 0.29 \text{ hour}$

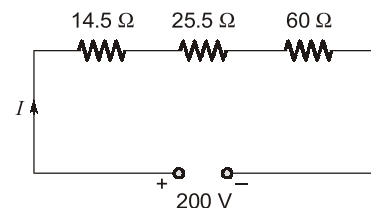
37. (c)

Current in the circuit is

$$I = \frac{V}{R} = \frac{200}{100} = 2 \text{ A}$$

$$\therefore V_{14.5\Omega} = I \times R$$

$$= 2 \times 14.5$$

$$= 29.0 \text{ V}$$

38. (b)

The circuit can be redrawn as shown below:

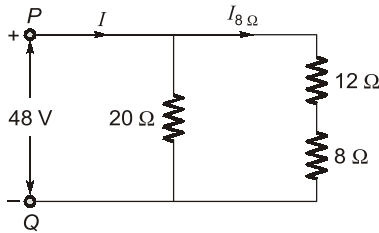

As $V = 48 \text{ V}$
 and $R = 12 + 8 = 20 \Omega$
 $\Rightarrow I_{8\Omega} = \frac{48}{20} = 2.4 \text{ A}$

39. (b)

When the supply is switched ON, the current drawn is more because more current is required during starting to create high voltage compared to that required by the ammeter in steady state.

40. (a)

$$\frac{1}{R_{eq}} = \frac{1}{2} + \frac{1}{4} + \frac{1}{5} + \frac{1}{20}$$

or, $\frac{1}{R_{eq}} = \frac{10 + 5 + 4 + 1}{20}$

$$\Rightarrow R_{eq} = \frac{20}{20} = 1 \Omega$$

41. (c)

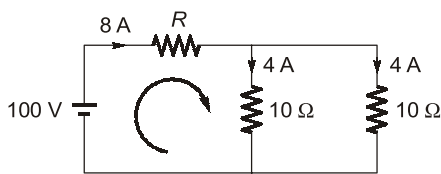

Current in 10Ω resistance = 4 A
 and $V_{10\Omega} = 40 \text{ V}$
 Applying KVL in 1st loop, we have:
 $100 - 8R - 40 = 0$
 $\Rightarrow 8R = 60$
 $\Rightarrow R = 7.5 \Omega$

42. (b)

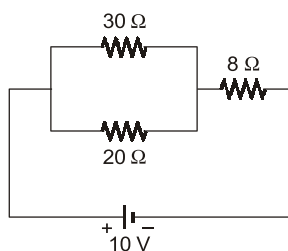

$$R_{eq} = (30 \parallel 20) + 8 = 20 \Omega$$

\therefore Power consumed,

$$P = \frac{V^2}{R_{eq}} = \frac{100}{20} = 5 \text{ W}$$

43. (a)

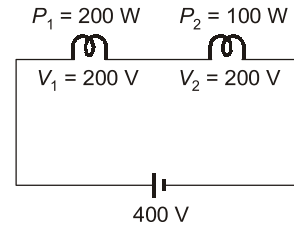

Here, $R_1 = \frac{V_1^2}{P_1} = \frac{200 \times 200}{200} = 200 \Omega$

$$R_2 = \frac{V_2^2}{P_2} = \frac{200 \times 200}{100} = 400 \Omega$$

In series connection current is same and power = $I^2 R$

$P_1 = I^2 R_1$
 and $P_2 = I^2 R_2$
 As resistance of 2nd bulb (100 W, 200 V) is more hence it draws more power and glows brighter.

44. (b)

If 4Ω is not disconnected,
 $R_{eq} = 6 + (4 \parallel 4) + 2$
 $= 10 \Omega$

If one 4Ω is disconnected,
 $R'_{eq} = 6 + 4 + 2$
 $= 12 \Omega$

As equivalent resistance is increasing after disconnecting 4Ω resistance, hence current decreases.

45. (b)

When, $V_S = 0, I = 3 \text{ A} = I_1$
 Now let, $I_S = 0$ and $V_S = 200 \text{ V}$

Then, $I_2 = \frac{-200}{50} = -4 \text{ A}$

Hence, current when both I_S and V_S are connected is
 $I = I_1 + I_2$
 (Using superposition theorem)
 $= 3 - 4$
 $= -1 \text{ A}$

46. (*)

Circuit can be redrawn as shown below.

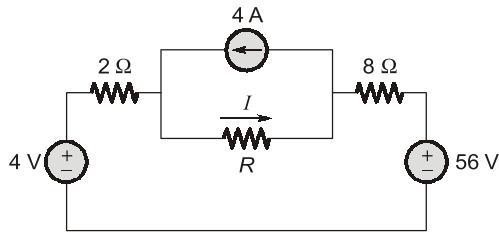
Value of R is missing. So it can't be solved.**47. (b)**Given, $R_A = 600 \Omega$; $R_B = 100 \Omega$ Resistance, $R = \frac{\rho l}{A}$ As ρ and A are same, therefore $R \propto l$.

$$\Rightarrow \frac{R_A}{R_B} = \frac{l_A}{l_B}$$

$$\Rightarrow \frac{l_A}{l_B} = 6$$

$$\Rightarrow l_A = 6 l_B$$

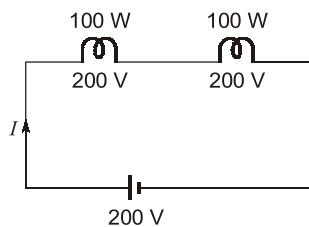
48. (b)

$$R_1 = \frac{V^2}{P} = \frac{200 \times 200}{100} = 400 \Omega = R_2$$

$$\therefore I = \frac{200}{800} = 0.25 \text{ A}$$

$$\text{Hence, } P_1 = I^2 R_1 = \left(\frac{1}{4}\right)^2 \times 400$$

$$= \frac{1}{16} \times 400 = 25 \text{ W}$$

As $R_1 = R_2$ and current is same in series, therefore,

$$P_1 = P_2 = 25 \text{ W}$$

49. (b)

Terminal where three or more branches meet is known as node.

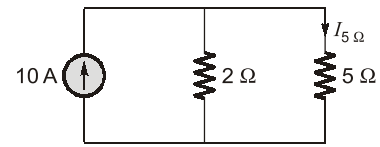
50. (d)

According to current division rule,

$$I_{5\Omega} = \frac{2}{7} \times 10 = 2.85 \text{ A}$$

51. (d)

We simplify the given figure as shown below:

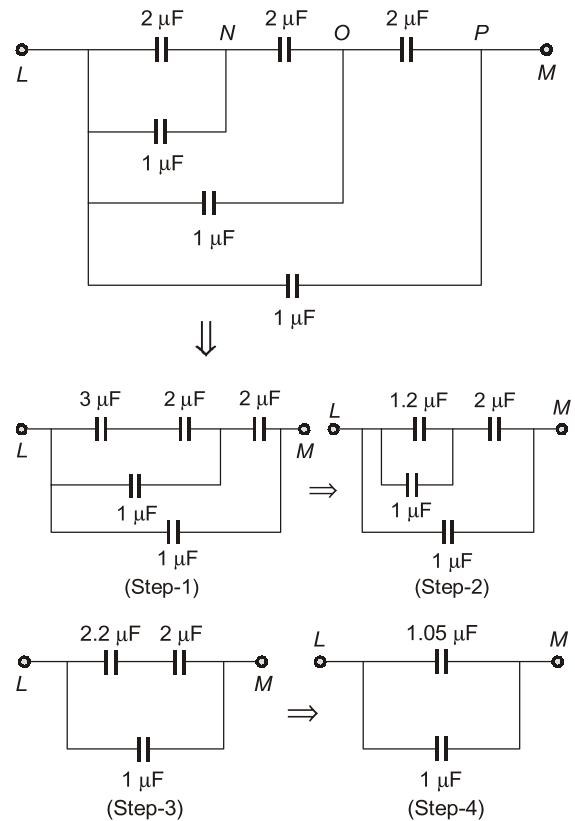
Hence, C_{eq} across the points L and M is

$$C_{eq} = 1.05 + 1 = 2.05 \mu\text{F}$$

52. (c)Given, $L_1 = 9 \text{ H}$; $L_2 = 4 \text{ H}$

Mutual inductance,

$$M = K\sqrt{L_1 L_2} \text{ and } K = 1 \text{ (Given)}$$

$$\Rightarrow M = \sqrt{36} = 6 \text{ H}$$

53. (c)

According to voltage divider rule,

$$V_c = \frac{50}{100 + 50} \times 120 = 40 \text{ V}$$

54. (a)

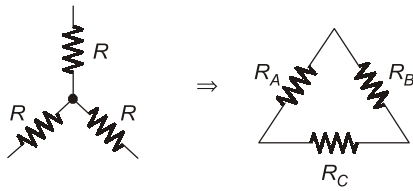

Here, $R_A = R_B = R_C$
(Since all resistors are equal in star connection)

$$\begin{aligned} \therefore R_A &= R_B = R_C \\ &= \frac{R \times R + R \times R + R \times R}{R} = 3R \end{aligned}$$

55. (d)

Normally, the bulbs are connected in parallel in house so same voltage can be assumed across them.

Given, $P_1 = 60 \text{ W}$ and $P_2 = 100 \text{ W}$

$$\text{Now, } P = \frac{V^2}{R} \Rightarrow P \propto \frac{1}{R}$$

$$\text{and } R = \frac{\rho l}{A}$$

$$\Rightarrow R \propto l \quad (\because \rho \text{ \& } A \text{ is same for both})$$

$$\therefore P \propto \frac{1}{l}$$

$$\Rightarrow \frac{P_1}{P_2} = \frac{l_2}{l_1} \Rightarrow \frac{l_2}{l_1} = \frac{60}{100} = \frac{3}{5}$$

Hence, 60 W bulb will have longer length.

56. (c)

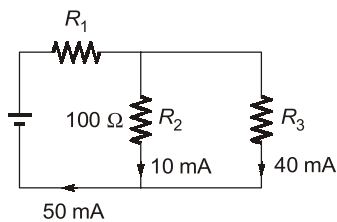

$$\text{Here, } V_{R_2} = 100 \times 10 \times 10^{-3} = 1 \text{ V} \quad \dots(i)$$

$$\text{Also, } V_{R_2} = V_{R_3} = 1 \text{ V} \\ = 40 \times 10^{-3} R^3 \quad \dots(ii)$$

Equation (i) and (ii),

$$1 = 40 \times 10^{-3} \times R^3$$

$$\Rightarrow R_3 = 25 \Omega$$

57. (d)

An ideal voltage source should have zero source resistance because no internal voltage drop must be present ideally.

58. (b)

$$\text{For } R = \infty; V = 20 \text{ V}$$

$$\Rightarrow V_{OC} = 20 \text{ V} = V_{Th}$$

$$\text{Also, for } R = 0; I = 4 \text{ A} = I_{SC}$$

$$\therefore R_{Th} = \frac{V_{OC}}{I_{SC}} = \frac{20}{4} = 5 \Omega$$

Thevenin's equivalent across 'R' is shown below.

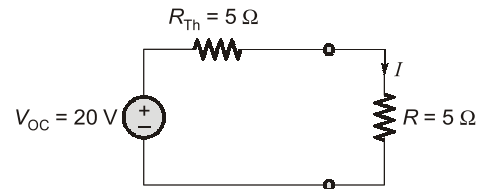

$$\text{Here, } I = \frac{20}{5 + 5} = 2 \text{ A}$$

59. (b)

Maximum power will be transferred to R_L .

when, $R_L = R_{Th}$

R_{Th} across R_L is obtained by open circuiting the current source.

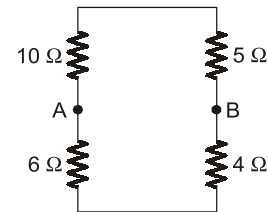

$$\begin{aligned} R_{AB} &= R_{Th} \\ &= (10 + 5) \parallel (6 + 4) = 6 \Omega \end{aligned}$$

60. (b)

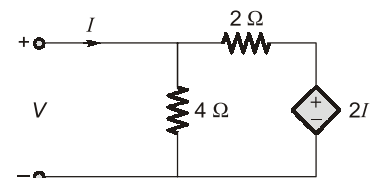

$$\text{Here, } I = \frac{V}{4} + \frac{V - 2I}{2}$$

$$\text{or, } 2I = \frac{3V}{4}$$

$$\Rightarrow \frac{V}{I} = \frac{8}{3} \Omega = R$$

Hence, the load resistance across the given input terminal is $R = \frac{8}{3} \Omega$ as shown below.

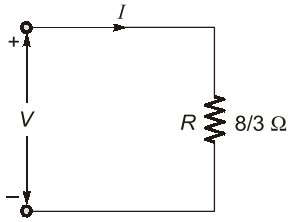

61. (a)

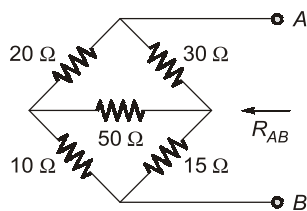

The circuit shown is a balanced Wheatstone bridge since arms ratio is same.

$$\text{i.e., } \frac{20}{10} = \frac{30}{15} = 2$$

Hence, no current flows through 50Ω resistance.

$$\therefore R_{AB} = (20 + 10) \parallel (30 + 15) \\ = 30 \parallel 45$$

$$\text{or, } R_{AB} = 18 \Omega$$

62. (d)

Susceptance is the imaginary part of the admittance.

$$\begin{aligned} \text{Here, } Y &= \frac{1}{3 + j4} + \frac{1}{5 - j10} = \frac{(8 - j6)}{(3 + j4)(5 - j10)} \\ &= \frac{8 - j6}{(55 - 10j)} \times \frac{(55 + 10j)}{(55 + 10j)} \\ &= \frac{440 + 80j - 330j + 60}{(55)^2 + (10)^2} \\ &= \frac{500 - 250j}{3125} = (0.16 - j0.08) \text{ S} \end{aligned}$$

Hence, susceptance = 0.08 S

63. (c)

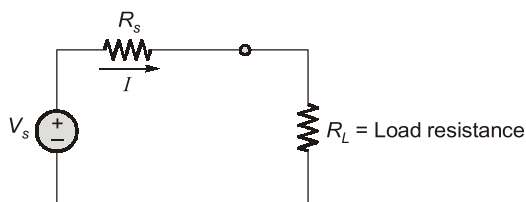

$$\% \eta = \left(\frac{P_{\text{out}}}{P_{\text{out}} + \text{Losses}} \right) \times 100$$

$$\text{or, } \% \eta = \frac{I^2 R_L}{I^2 R_S + I^2 R_L} \times 100$$

$$\text{or, } \% \eta = \frac{R_L}{R_S + R_L} \times 100$$

For maximum power transfer,

$$R_L = R_S$$

$$\Rightarrow \% \eta = \left(\frac{R_S}{R_S + R_S} \right) \times 100 = 50\%$$

64. (d)

Superposition theorem can be applied only to linear bilateral networks.

65. (b)

Using Millman's theorem, the equivalent circuit across R_L has

$$R_{\text{eq}} = \frac{1}{\frac{1}{3} + \frac{1}{3} + \frac{1}{3}} = 1 \Omega$$

$$V_{\text{eq}} = \frac{\frac{8}{3} + \frac{16}{3} + \frac{24}{3}}{\frac{1}{3} + \frac{1}{3} + \frac{1}{3}} = 16 \text{ V}$$

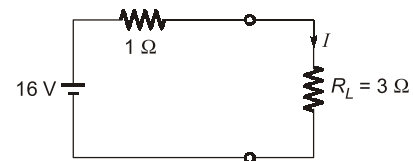

$$\therefore I = \frac{16}{4} = 4 \text{ A}$$

66. (c)

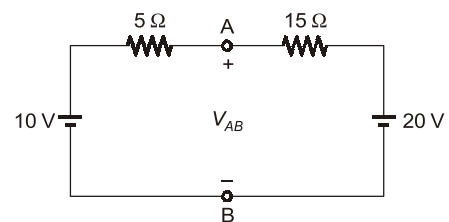

Applying KCL, we have:

$$\frac{V_{AB} - 10}{5} + \frac{V_{AB} - 20}{15} = 0$$

$$\left(\begin{array}{l} V_B = 0 \dots \dots \text{reference} \\ \therefore V_{AB} = V_A \end{array} \right)$$

$$\text{or, } 3V_{AB} - 30 + V_{AB} - 20 = 0$$

$$\text{or, } 4V_{AB} = 50$$

$$\Rightarrow V_{AB} = 12.5 \text{ V}$$

$$\text{Also, } R_{\text{Th}} = R_{AB} = (15 \parallel 5) = 3.75 \Omega$$